

Rowan University

## Rowan Digital Works

---

Theses and Dissertations

---

9-18-2014

### Use of blood oxygenator membrane units in teaching mass balances, friction factor and mass transfer analysis

Keith McIver

Follow this and additional works at: <https://rdw.rowan.edu/etd>



Part of the [Chemical Engineering Commons](#)

---

#### Recommended Citation

McIver, Keith, "Use of blood oxygenator membrane units in teaching mass balances, friction factor and mass transfer analysis" (2014). *Theses and Dissertations*. 15.

<https://rdw.rowan.edu/etd/15>

This Thesis is brought to you for free and open access by Rowan Digital Works. It has been accepted for inclusion in Theses and Dissertations by an authorized administrator of Rowan Digital Works. For more information, please contact [graduateresearch@rowan.edu](mailto:graduateresearch@rowan.edu).

**USE OF BLOOD OXYGENATOR MEMBRANE UNITS IN TEACHING MASS  
BALANCES, FRICTION FACTOR AND MASS TRANSFER ANALYSIS**

by

Keith Andrew McIver

A Thesis

Submitted to the

Department of Chemical Engineering

College of Engineering

In partial fulfillment of the requirement

For the degree of

Master of Science in Engineering

at Rowan University

May 20, 2014

Thesis Chair: Stephanie Farrell, Ph. D.

© 2014 Keith Andrew McIver

## **Acknowledgements**

Professors Stephanie Farrell and Thomas Lad Merrill advised the author throughout the project and ensured the results, both physical and educational, were of a high standard. Marvin Harris taught, explained and suggested how to construct the system described here. The quality of construction is greatly due to his help. Mark Recupero of WGS Instruments went out of his way to help troubleshoot and explain the dissolved oxygen instrumentation he sold the project. Without his information and assistance the laboratories described here would not be on nearly as sound a footing. Rui Wang, Allyson White, Bayan Mazahreh and Michael Lewis all assisted in designing, building and testing the final system layout and revising instruction manuals and laboratory handouts. Michelle Ucci and Austin Wilkinson assisted with the text revisions as well.

Medtronic Incorporated donated the blood oxygenator units used in the system described in this thesis. The National Science Foundation financially supported the work described in this thesis via grant DUE 1140631. Their support of engineering education is appreciated.

## Abstract

Keith Andrew McIver

### USE OF BLOOD OXYGENATOR MEMBRANE UNITS IN TEACHING MASS BALANCES, FRICTION FACTOR AND MASS TRANSFER ANALYSIS

2010-2014

Stephanie Farrell, Ph. D.

Thomas Lad Merrill, Ph. D.

Master of Science in Chemical Engineering

Many applications of chemical engineering principles are biomedical but traditional chemical engineering education does not focus on these applications. New laboratory experiments with hollow fiber blood oxygenators allow integration of concepts into already full programs.. This work describes three new educational experiments that have been developed to introduce students to concepts of mass balances, mass transfer and momentum transfer as applied to a hollow fiber blood oxygenator. In addition, a new mass transfer correlation is presented for the Medtronic Affinity NT blood oxygenator, which has not been reported previously in the literature.

Mass transfer of oxygen through the hollow fiber membranes is determined from measurements of the oxygen present in each stream crossing the system boundary and applying a mass balance. At 3.78 L/min of blood analog flow and 1 SCFH of oxygen delivery, a mass transfer of 70 mg/min was observed.

Liquid pressure drop through the oxygenator is measured by calibrated pressure transducers and recorded in a spreadsheet. Analyzing the data produces a correlation between the Fanning friction factor and Reynolds number of  $f = 8.1/Re^{0.12}$  instead of predicted  $f = 16/Re$  and manufacturer's data of  $f = 17.8/Re^{0.89}$ .

A mass transfer correlation from dissolved oxygen concentrations was developed using the dimensionless Reynolds, Sherwood and Schmidt numbers:  $Sh/Sc^{0.333} = 0.223Re^{0.338}$ .

## Table of Contents

Abstract	iv
List of Figures	viii
List of Tables	xi
Chapter 1: Introduction	1
Chapter 2: Testing system	6
2.1 Description of the blood oxygenator testing system	6
2.2 Operation of the blood oxygenator testing system	12
2.2.1 Introduction of blood analog.	12
2.2.2 Startup	13
2.2.3 Changing blood analog flowrate	13
2.2.4 Dissolved oxygen data collection	14
2.2.5 Oxygen-in-gas data collection	14
2.2.6 Pressure drop measurement	15
2.2.7 Cleanup and shutdown	16
Chapter 3: Nomenclature	17
Chapter 4: Mass transfer rate	19
4.1 Background	20
4.2 Experimental procedure	23
4.3 Sample results	24
4.3.1 Student learning	27
Chapter 5: Pressure drop	33
5.1 Background	34
5.2 Experimental procedure	38
5.3 Sample results	39
Chapter 6: Mass transfer correlation	41
6.1 Background	42
6.2 Experimental procedure	44
6.3 Sample results	45
Chapter 7: Summary	47
List of references	49

Appendix A Raw pressure data for BA50 at 1 GPM	53
Appendix B Laboratory procedure for mass transfer rate experiment	59
Appendix C Evaluation questions for experiment one	75
Appendix D Laboratory procedure for friction factor experiment	79
Appendix E Laboratory procedure for mass transfer correlation experiment	84



## List of Figures

- Figure 1. Normal circulation (left) and cardiopulmonary bypass using a heart-lung machine (right). In normal circulation, air is inhaled by the lungs (L) where mass transfer to the blood occurs and the heart (H) pumps the blood through the body (B). In bypass, a pump (P) moves blood through a blood oxygenator membrane unit (M) and the heart and lungs are not used. 3
- Figure 2. Flow diagram of the system. Instrumentation is present around the oxygen-supplied membrane, as shown in Figure 5. All liquid tubing is  $\frac{3}{8}$ " ID Tygon except for the tank-pump line, which is  $\frac{1}{2}$ " ID Tygon. All gas tubing is  $\frac{1}{4}$ " OD rigid nylon except where connecting to the unit ports (Table 2). 6
- Figure 3. The blood oxygenator testing system. Height is approximately 2.1 m. The oxygenation (OX) and deoxygenation (DEOX) membranes are connected in series. Flowrates of nitrogen, oxygen and blood analog are read from the flowmeters labeled FN, FO and FL. Dissolved oxygen concentration in the liquid entering and exiting oxygenation membrane is determined by the two sensor-transmitter loops (DO1 and DO2 respectively). Pressure transducers attached to inlet and outlet lines (black box) are checked against a liquid manometer (M) and read on the PC. 7
- Figure 4. Medtronic Affinity NT blood oxygenator unit [12]. Venous blood flows in at the bottom (V), up through the heat exchanger (HX), outward through the hollow fiber membrane bundle (HFM) and exits as arterial blood (A). Oxygen gas enters at the top (O-in) and exits at the lower port (O-out). Heat exchanger water is connected to the lower right ports (HXW). 9
- Figure 5. Flow (trapezoids), pressure (P), dissolved oxygen (DO) and oxygen-in-gas (OG) instruments are located around the oxygenator. 11
- Figure 6. Oxygen-in-gas instrumentation on the control panel. Valves (V) divert the gas streams entering and exiting the membrane unit to the sensor (S). Mass percentage of oxygen in the gas stream is read on the transmitter (T). 15
- Figure 7. Oxygen mass flows entering and exiting a membrane unit. Horizontal and numbered streams (1 and 2) are liquid, vertical and lettered streams (A and B) are gas. 21
- Figure 8. Blood oxygenator labeled with variables used in Equation (4). Central arrow indicates oxygen mass transfer across membrane, calculated using Equations (5) and (6). 22

Figure 9. Standard error of the mean on the mass transfer rates across the membrane. Both values are an average of three data points. Students are expected to conclude that the mass transfer rates are statistically not different.	26
Figure 10. Average gains on assessment questions. The questions themselves are shown in Appendix C – Evaluation questions for experiment one.	30
Figure 11. Class average normalized gain by question using Equation (7).	31
Figure 12. Medtronic Affinity NT fluid flows [24] in cutaway view. Blood from the heat exchanger (I) enters the central riser column and flows down the inner gap. The parallel arrows are the liquid flows through the woven hollow fiber mat, shown in gray. Their velocity is calculated using Equation (15). Oxygenated blood is collected at a side port (O).	36
Figure 13. Friction factor of all blood analogs as a function of the Reynolds number (light gray diamonds) and the manufacturer’s published data (solid dark triangles). Manufacturer data does not indicate the source or properties of the fluid used in their tests. Dashed lines are $f = 16/Re$ for flow through the fiber lumen (upper left) the empty mass transfer chamber (lower right), showing friction effects for flow through the fiber mat. Uncertainty analysis was not performed because the collected data is believed to be erroneous.	39
Figure 14. Correlations between Sherwood, Schmidt and Reynolds numbers showing mass transfer in the Medtronic Affinity NT oxygenator. Diamonds represent new data from this experiment. Squares show adaptation of manufacturer’s mass transfer data. The root mean square (RMS) error of the correlation is 0.0478 and the bias is -0.00291.	46
Figure 15. Actual data from a journal article (Stamatialis et al., Journal of Membrane Science, 2008) showing mass transfer in membrane. “mmHg” (millimeters of mercury) refers to the partial pressure of the gases in the blood, a proxy for their concentration. “cm <sup>3</sup> (STP) / min” (cubic centimeters at STP per minute) is a volumetric flow rate.	61
Figure 16. Block diagram of the system. Instrumentation and controls are not shown.	62
Figure 17. Detailed diagram of the system	63
Figure 18. Valves on the oxygen cylinder. Turning the regulator valve clockwise will OPEN it, not close it. The stem valve should not be opened more than a quarter turn. Excess opening takes unnecessary time to close, such as in an emergency. LP gage indicates pressure of gas delivered to the system; HP gage indicates pressure in the cylinder.	65

Figure 19. Flow variables and concentrations crossing a system boundary drawn around the oxygenator.	73
Figure 20. Block diagram of the system. Instrumentation and controls are not shown.	80
Figure 21. Drawing of system front panel	86
Figure 22. Blood oxygenator membrane unit. This unit is used to oxygenate the blood analog. An identical one is used to deoxygenate the blood analog.	87
Figure 23. The oxygenator testing system. Concentration sensors, flow meters, manometer and membrane units are mounted on the front panel. The nitrogen and oxygen gases are supplied by the cylinders seen behind the assembly. The pump rests on the table behind the panel and pumps the blood analog from the holding tank through the two membranes and back to the tank.	88
Figure 24. Valves on the oxygen cylinder. Turning the regulator valve clockwise will OPEN it, not close it. The stem valve should not be opened more than a quarter turn. Excess opening takes unnecessary time to close, such as in an emergency. LP gage indicates pressure of gas delivered to the system; HP gage indicates pressure in the cylinder.	89

## **List of Tables**

Table 1. Composition of blood analogs	8
Table 2. Specifications of the Affinity NT blood oxygenator unit [8] [12].	8
Table 3. List of major equipment information with costs.	11
Table 4. Nomenclature table. Variables are consistent across experiments. Only variables obtained from instruments will have recorded units.	17
Table 5. Uncertainties of instruments used in calculating the mass transfer rates out of the gas phase and into the liquid phase. The sample reading provided for the dissolved oxygen sensor is required to calculate the absolute uncertainty.	25
Table 6. Liquid blood analog flowrates used in Experiment 2.	38
Table 7. Liquid blood analog flowrates used in Experiment 3.	44
Table 8. System values for calculations.	94

## Chapter 1: Introduction

Biomedical applications of chemical engineering are widespread. Medical devices contain materials produced by chemical engineers and many operate using chemical engineering principles such as mass transport, heat transfer, momentum transfer or chemical reactions. The skills and knowledge of chemical engineers are needed to design, test, produce and support these devices. Engineering ethics, in complement to medical ethics, must be continuously integrated into decision making from the initial outlining to final withdrawal from the market. Medicine is improved by the integration of biology into engineering.

Chemical engineers have made essential contributions toward the advancement of medicine in several areas, including the development of novel controlled drug delivery systems for therapeutic proteins [1] of nanomaterials for tissue engineering [2], immune white blood cell replacement in bone marrow transplantation [1] complex analysis of the human body [3] and engineering of proteins [4]. The entire field of biomanufacturing applies chemical engineering knowledge and design thinking to the industrial production of therapeutic agents [5]. For the last fifty years, chemical engineers have made pioneering contributions toward advancing the biomedical industry [6], which is expected to grow 26.6 percent in the United States between 2012 and 2022 [7]. Students internationally express a strong interest in working in this field after graduation [8]. In response to these trends, chemical engineering programs have begun adding biology content and course requirements. Approaches include use of a required engineering-focused biology course [9], integration of material into existing course lectures [10] and creation of minors or concentrations in biotechnology [11].

Integrating new biomedical content into current curricula is challenging. Existing chemical engineering programs are notoriously crowded, making an additional course a difficult proposition for many colleges. Accreditation entities require student performance in a wide range of topic areas besides core technical knowledge. Common expectations include ethics and professional responsibility, communication and awareness of current issues [12] [13] [14]. When introducing new material, these existing outcomes cannot be compromised.

A synthesis of these options is the use of laboratory experiments covering biomedical applications of chemical engineering and including them directly in the existing courses. This provides the pedagogically sound benefits of concrete, real-world applications and hands-on learning experiences [15]. Students who perform experiments are shown to attain a greater understanding than if only written problems are used. Instructors report deeper understanding of the material themselves [16]. This thesis presents three experiments using biomedical processes and equipment that may be used to teach basic concepts in chemical engineering. Preliminary student testing has shown positive results, but a rigorous analysis has not been conducted at this time.

The experiments are based on the analysis of a blood oxygenator membrane unit in a heart-lung machine. Heart-lung machines are medical devices that temporarily pump and oxygenate blood in place of the human heart and lungs (Figure 1) during operations which require a non-beating, blood-free heart. Heart transplant, coronary bypass and valve replacement are common surgeries requiring this. This temporary takeover of functions is called cardiopulmonary bypass or CPB. The experiments will cover

membrane mass transfer rate calculation, pressure drop through the membrane unit and the determination of empirical mass transfer correlation coefficients.

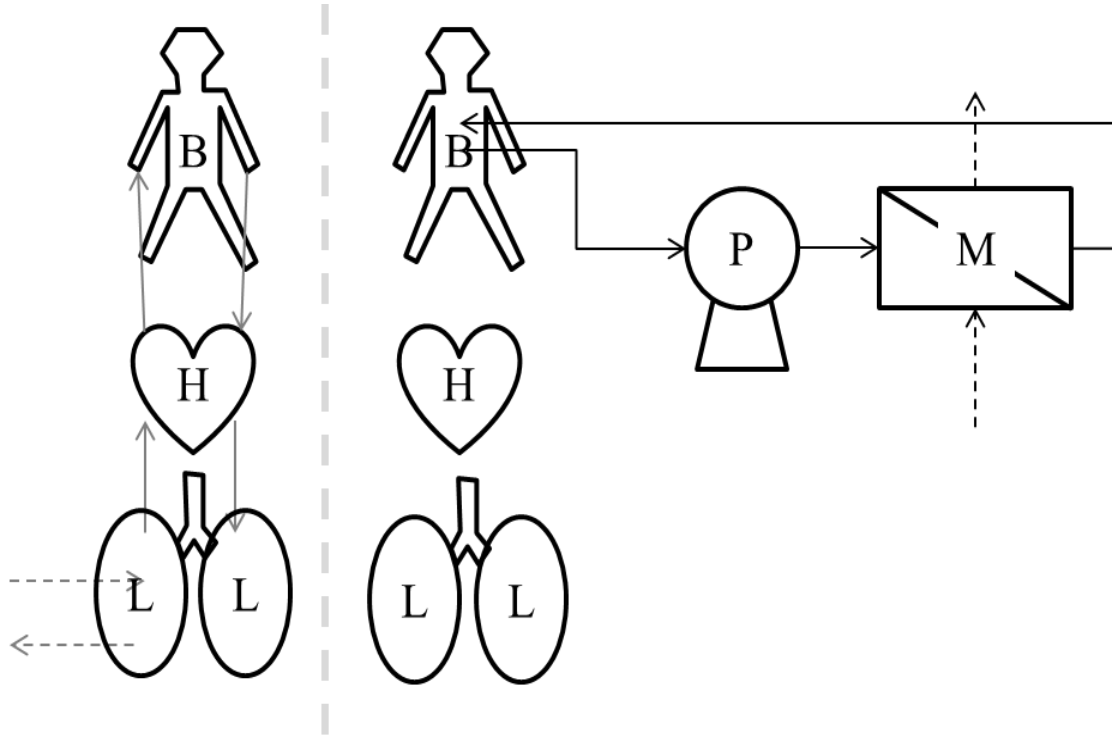

Figure 1. Normal circulation (left) and cardiopulmonary bypass using a heart-lung machine (right). In normal circulation, air is inhaled by the lungs (L) where mass transfer to the blood occurs and the heart (H) pumps the blood through the body (B). In bypass, a pump (P) moves blood through a blood oxygenator membrane unit (M) and the heart and lungs are not used.

Blood oxygenator design is based around several constraints to fluid flow mechanics. Blood oxygenators should have a Darcy permeability of approximately  $10^{-5}$   $\text{cm}^2$  [17], have transmembrane pressure difference less than 300 mm Hg [18] and not induce turbulent flow in the blood [17] [18]. Low resistance to gas transfer allows blood and oxygen to be supplied at a lower pressure to the oxygenator, which in turn reduces the transmembrane pressure difference and reduces the risk of gas bubbles being

introduced to the blood. Turbulence causes high shear and hence blood trauma. The testing system described in this thesis may be used to determine values of mass transfer across the membrane, pressure drop through the unit and Reynolds numbers. A blood analog is pumped through the membrane unit and oxygen gas is supplied to it instead of blood.

Because CPB is commonly performed (In 2008 an estimated 2,000 bypass operations occurred daily [19]) the membrane units are widely studied [19] [20] [21] with both manufacturer data and literature correlations are available. These allow comparison of student data to real-world benchmarks and expose students to data and methods of presentation used in research and industry which present data indirectly, such as in dimensionless number correlations, and require interpretation.

The three laboratory experiments presented can be used in the courses of a chemical engineering curriculum that cover mass balances, fluid flow and mass transfer. The first experiment, shown in Chapter Chapter 4:, is appropriate for an introduction to engineering course or a mass balance course. This experiment covers mass balances, process instrumentation, laboratory safety and mass transfer.

The second laboratory experiment, detailed in Chapter Chapter 5:, is designed for a fluid mechanics course and teaches about fluid flow, friction factor, data acquisition and the Reynolds number.

The third experiment, described in chapter Chapter 6:, is intended for a mass transfer course or unit operations laboratory. It introduces the students to the use of Sherwood-Reynolds-Schmidt number correlations and their use in the description and



analysis of mass transfer data. Each experiment is independent of the others and of any particular lesson plan or textbook.

## Chapter 2: Testing system

### 2.1 Description of the blood oxygenator testing system

The system is a continuous closed loop of blood analog (BA) liquid pumped through two blood oxygenator units in series. Oxygen gas is supplied to the first oxygenator and nitrogen to the second, resulting in oxygenation and deoxygenation in a continuous loop, shown in Figure 2.

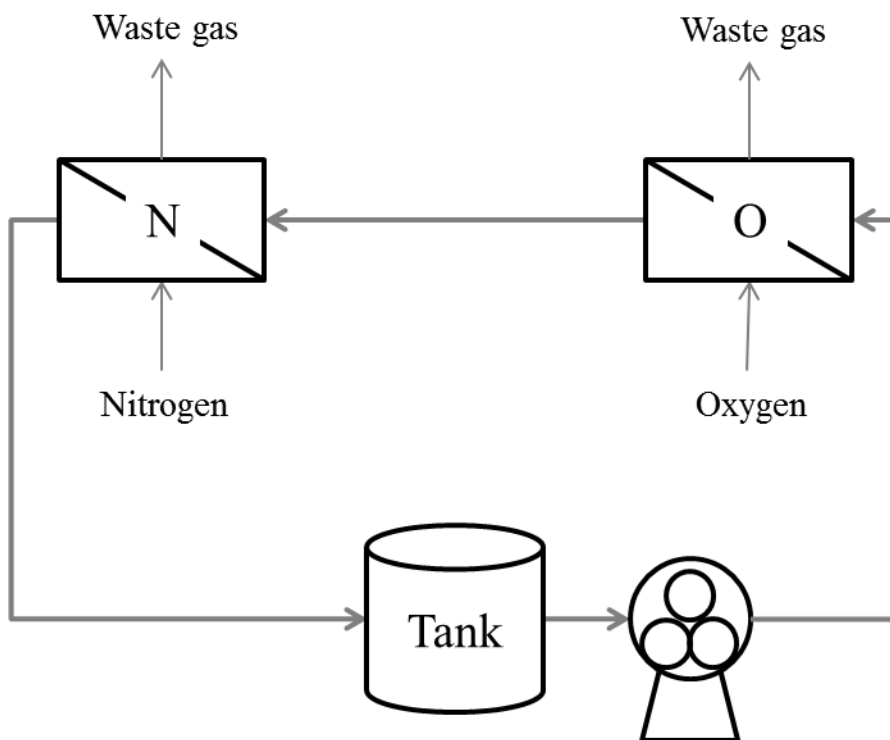

Figure 2. Flow diagram of the system. Instrumentation is present around the oxygen-supplied membrane, as shown in Figure 5. All liquid tubing is  $\frac{3}{8}$ " ID Tygon except for the tank-pump line, which is  $\frac{1}{2}$ " ID Tygon. All gas tubing is  $\frac{1}{4}$ " OD rigid nylon except where connecting to the unit ports (Table 2).

The system is shown in Figure 3. This bench-top unit incorporates a clinical membrane blood oxygenator unit and allows real-time measurement of concentration, flow rate and pressure drop.

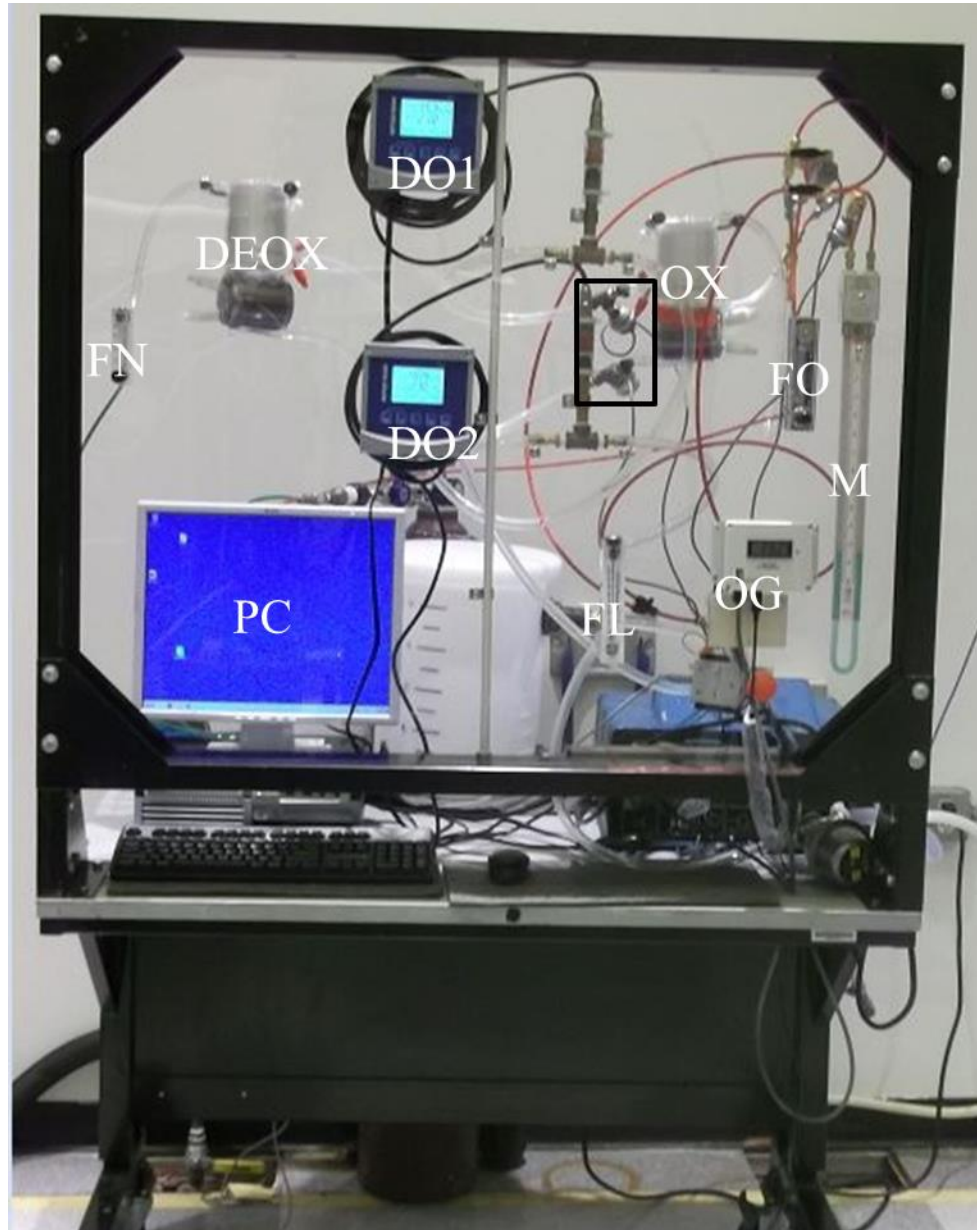

Figure 3. The blood oxygenator testing system. Height is approximately 2.1 m. The oxygenation (OX) and deoxygenation (DEOX) membranes are connected in series. Flowrates of nitrogen, oxygen and blood analog are read from the flowmeters labeled FN,

FO and FL. Dissolved oxygen concentration in the liquid entering and exiting oxygenation membrane is determined by the two sensor-transmitter loops (DO1 and DO2 respectively). Pressure transducers attached to inlet and outlet lines (black box) are checked against a liquid manometer (M) and read on the PC.

The blood analog in the first experiment (Chapter Chapter 4:) is tap water. In the other two experiments glycerin and water mixtures (Table 1) are used to obtain a wider range of physical properties. Blood is not used because of the expense and danger of having potentially pathogenic material present.

Table 1. Composition of blood analogs

Blood analog number	Mass percent water	Mass percent glycerin
BA100	100	0
BA95	95	5
BA90	90	10
BA80	80	20
BA70	70	30
BA60	60	40
BA50	50	50

The membrane unit is an Affinity NT (Medtronic Inc., Minneapolis, MN) oxygenator. This is a microporous hollow fiber system with an attached bellows type heat exchanger (the heat exchanger is not used in the experiments described in this thesis). Specifications are given in Table 2 and a promotional image with added scale marking is shown in Figure 4.

Table 2. Specifications of the Affinity NT blood oxygenator unit [8] [12].

Membrane type and material	Microporous polypropylene
Membrane surface area	2.5 m <sup>2</sup>
Static priming volume	270 mL

Recommended blood flow rate	1 to 7 L/min
Arterial outlet port	$\frac{3}{8}$ in.
Venous inlet port	$\frac{3}{8}$ in.
Recirculation port	$\frac{1}{4}$ in.
Gas inlet port	$\frac{1}{4}$ in.
Gas outlet port	$\frac{3}{8}$ in.
Gap between fiber bundle and outer wall	$\frac{1}{8}$ in.
Gap between fiber bundle and inner column	$\frac{1}{6}$ to $\frac{1}{8}$ in.
Fiber bundle thickness	$\frac{7}{8}$ in.
Inner diameter of the fiber bundle	$1\frac{1}{4}$ in.
Outer diameter of the fiber bundle	3 in.
Effective fiber length	3 in.

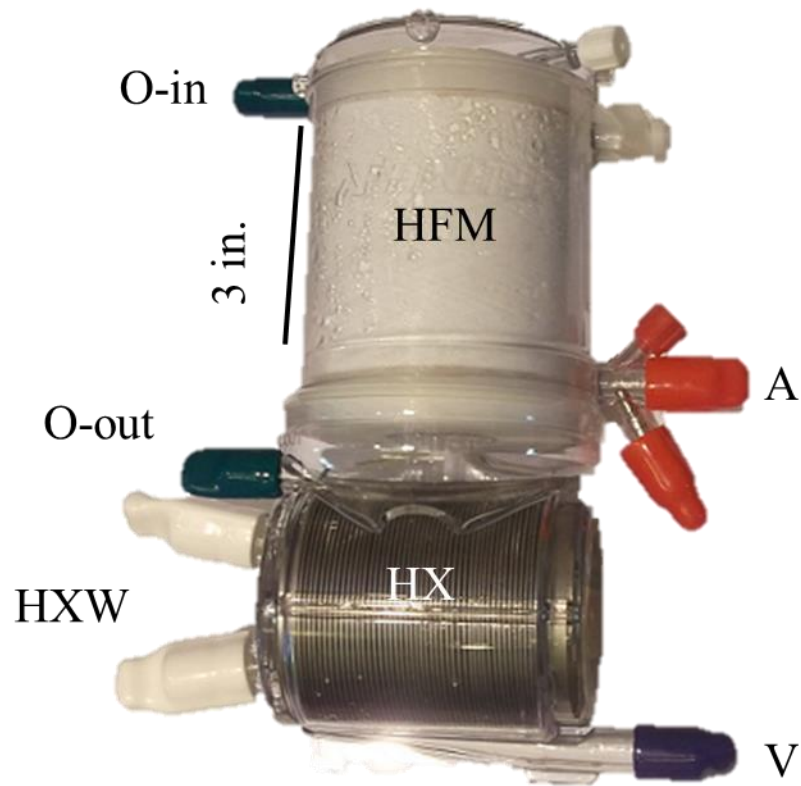

Figure 4. Medtronic Affinity NT blood oxygenator unit [12]. Venous blood flows in at the bottom (V), up through the heat exchanger (HX), outward through the hollow fiber membrane bundle (HFM) and exits as arterial blood (A). Oxygen gas enters at the top (O-

in) and exits at the lower port (O-out). Heat exchanger water is connected to the lower right ports (HXW).

The system contains three types of instrumentation: flow, pressure and oxygen concentration. Each of the three flow streams (blood analog, nitrogen and oxygen) have rotameters (7520-2-1-0-3C-06, 7520-2-1-0-2C-03, 74C-1-23-G-081-1-2-1-5-1-0 respectively, King Instrument Co., Garden Grove, CA) installed for direct flow reading. Pressure transducers (EW-68075-40, Cole-Parmer, Vernon Hills, IL) are installed on all lines entering and exiting the blood oxygenator under study and are sampled by an NI-6008 data acquisition device and displayed by the LabVIEW software package (both National Instruments, Austin, TX) on an attached PC. A manometer is installed across the oxygenator on the oxygen line as a check on the transducer readings. An OXY-SEN oxygen-in-gas sensor (Alpha-Omega Instruments, Lincoln, RI) allows the students to determine the volume percent oxygen entering the system from the oxygen source and exiting the blood oxygenator. InPro 6050 dissolved oxygen sensors and M300 transmitters (both Mettler-Toledo Ingold, Bedford, MA) indicate the concentration of oxygen in the blood analog liquid as it enters and exits the oxygenator. The location of these instruments is shown schematically in Figure 5.

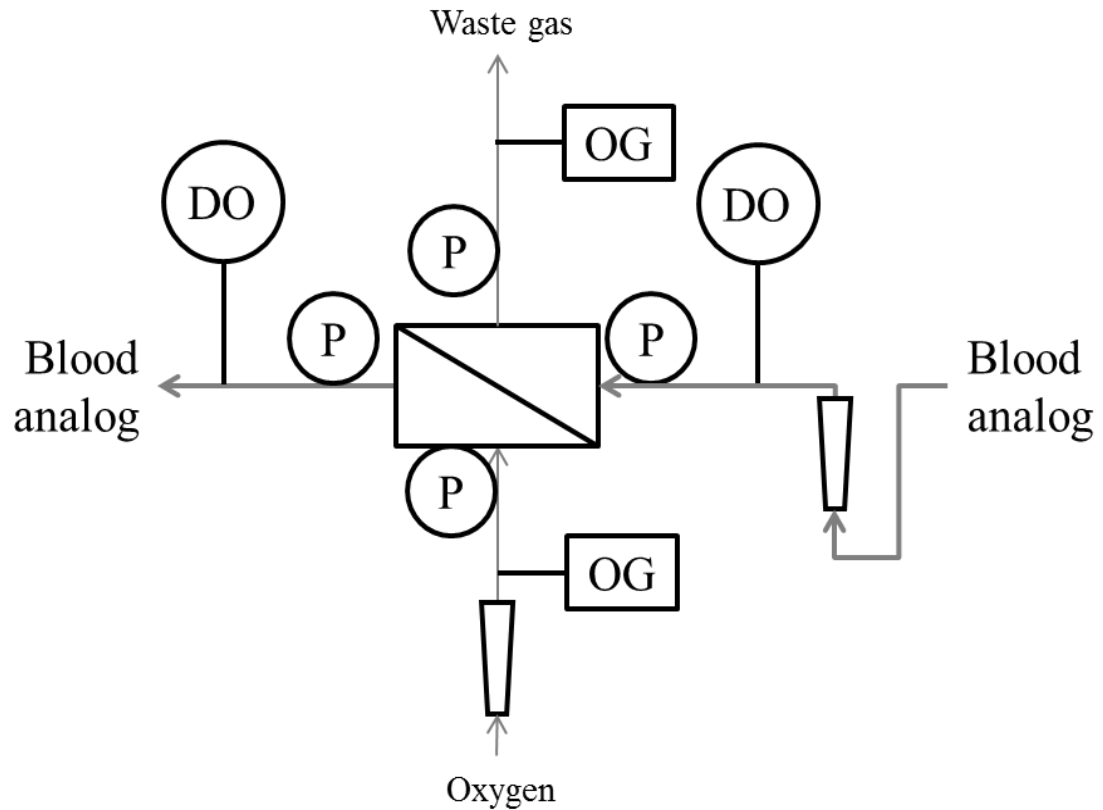

Figure 5. Flow (trapezoids), pressure (P), dissolved oxygen (DO) and oxygen-in-gas (OG) instruments are located around the oxygenator.

The total cost of the system came to under 5000 USD because several critical components such as the pump, table, PC and software were provided by the laboratory or department. The most expensive items by far were the two dissolved oxygen sensors and transmitters. A summary of costs and items is given in Table 3.

Table 3. List of major equipment information with costs.

Component	Manufacturer	Address	Model	Cost (USD)
Table	Fisher	De Pere, WI	Smart table	0.00 (*)
Pump	Watson-Marlow	Falmouth, UK	701U/R	0.00 (*)

Component	Manufacturer	Address	Model	Cost (USD)
Membrane units	Medtronic	Minneapolis, MN	Affinity NT	0.00 (**)
Valves and fittings	McMaster-Carr	Elmhurst, IL	(various)	373.46 (*)
Flow instrumentation	King Instrument Co.	Garden Grove, CA	(various)	436.09
Oxygen-in-gas sensor/transmitter	Alpha-Omega	Lincoln, RI	OXY-SEN	900.00
Dissolved oxygen sensors/transmitters	Mettler-Toledo Ingold	Bedford, MA	InPro6050 and M300 O2	2293.00
Pressure sensors	Cole-Parmer	Vernon Hills, IL	EW-68075-40	616.00
Data acquisition	National Instruments	Austin, TX	NI-6008 and LabVIEW 2012	189.00 (*)

(\*) – Excludes cost of parts available from department or laboratory

(\*\*) – Donated by Medtronic

The dimensions of the system are approximately 2.1 m × 1.2 m × 0.6 m (H × W × D) and the bench has wheels. The system is self-contained except for requiring sources of electric power (125 V<sub>AC</sub>) and nitrogen and oxygen gas (2.5 and 2.0 SCFH respectively). This allows easy movement into different classrooms and laboratory rooms as required for instruction and storage when not needed. The system produces nitrogen and oxygen off-gases at rates not higher than 2.5 SCFH. It should only be used in locations with an air change rate of 8 hr<sup>-1</sup> or with a spot ventilation system (elephant's trunk).

## 2.2 Operation of the blood oxygenator testing system

### 2.2.1 Introduction of blood analog.

The system initially has no blood analog in the tank or lines. The first step in operating the system is to generate the correct BA and introduce it into the system. A supplemental mixing tank is used. Between 5 and 7 liters of tap water is poured into this tank. If BA100 is being used, it is transferred directly to the system or holding tank. If glycerin is being



mixed in, the water is weighed and the mass of glycerin needed is calculated from the mass fraction. This amount is then poured into the mixing tank and agitated until a homogenous solution is formed. The mixture is then poured into the holding tank and the mixing tank rinsed thoroughly.

### **2.2.2 Startup**

After the new analog is in the holding tank, the system is ready for startup. First the pump is turned on at a low speed (less than 30 on the control dial) to check for leaks. If none are present, the speed is increased until 1.3 GPM is read on the rotameter. The students must check all the liquid flow lines for bubbles and purge any that are present by raising and lowering the tubing, pinching the tubing, or adjusting the speed of the pump.

Next, the oxygen and nitrogen cylinders are opened and the regulators set to approximately 100 kPa delivery pressure. This is a convenient pressure for students to aim for, but not the actual delivery pressure to the oxygenators. Two rotameters with integrated valves are used to set the actual flowrates into each oxygenator. The nitrogen delivery is always set to 2.5 SCFH; the oxygen flowrate varies in Experiment 1 and is constant at 1 SCFH in the others.

### **2.2.3 Changing blood analog flowrate**

The flowrate of blood analog is not controlled on the flowmeter, but on the pump control panel. This is separate from the front panel shown in Figure 3, but can be seen as the blue object behind the lower right of the front panel. The control is graduated from 0 to 100 % of full output, with full output being 2.5 GPM. To set the flowrate, the operator changes the dial while an assistant reads the front mounted flowmeter. Because the pump

is a peristaltic pump, the flow at low flowrates will be pulsatile. The average flow rate (mean of maximum and minimum when the control is at a single percentage) is recorded as the flowrate.

#### **2.2.4 Dissolved oxygen data collection**

The dissolved oxygen content of the blood analog streams entering and exiting the oxygenator are continuously displayed on the two dissolved oxygen transmitters mounted on the front panel. Students record the values on the readouts when they have reached steady state. When the blood analog is water, the transmitter is set to display concentration in milligrams dissolved oxygen per liter of solution and when these values change by less than 0.10 mg/L in 60 seconds, the system is taken to be at steady state.

Because the transmitter calculates a concentration based on the saturation characteristics of pure water, the concentration displayed must be adjusted to account for the difference between pure water and the water-glycerin mixture. The necessity for manual correction of the displayed concentration can be avoided by displaying the measured value in percentage saturation and using this value directly. When the percent saturation value changes by less than 0.20% in 60 seconds, the system is arbitrarily considered to be at steady state.

#### **2.2.5 Oxygen-in-gas data collection**

There is a single oxygen-in-gas sensor and transmitter that is used to take the levels of oxygen in both the feed and outlet streams. Three-way valves are present in the inlet and outlet lines. See Figure 6. These valves, when set, divert the entire flow to the sensor. To save time, the feed oxygen-in-gas level is recorded once and assumed constant

throughout the experimental run. This assumption is justified by noting the oxygen source is a commercial cylinder and assumed a homogenous mix. The outlet gas oxygen level is continuously measured by setting the gas outlet sampling valve and reading the value when it has reached steady state. Steady state is assumed when the reading fluctuations stabilize to  $\pm 2.0\%$  of a value.



Figure 6. Oxygen-in-gas instrumentation on the control panel. Valves (V) divert the gas streams entering and exiting the membrane unit to the sensor (S). Mass percentage of oxygen in the gas stream is read on the transmitter (T).

### **2.2.6 Pressure drop measurement**

Pressure drop through the membrane oxygenator is measured using the pressure transducers and the sampling software (LabVIEW) on the PC. The PC is configured to allow the software to be run by students with their university-issued network usernames

and without needing administrative power. When run, the software displays two virtual manometers showing pressure drop across the liquid side and across the gas side of the blood oxygenator. An actual gas-over-liquid manometer is provided across the gas side for illustration to the students and as a check on the transducer calibration. Once steady state is reached, the student signed in to the PC will select a filename and location to save the data to, and LabVIEW will record five seconds of raw data pressure data to a CSV (comma-separated values) file. Appendix A Raw pressure data for BA50 at 1 GPM contains a sample of raw data recorded by LabVIEW.

### **2.2.7 Cleanup and shutdown**

To prevent microbial growth in the system and especially within the membrane units, the system must be cleaned after use. If glycerin has been used at all, the blood analog is drained and the liquid flow path rinsed with water using the procedure in Section 2.2.2 and then drained again. Both oxygenator units are purged with nitrogen after draining.

Shutdown is performed by closing the stem valves on both cylinders and bleeding the pressure out of the lines, turning off the pump and correctly shutting down the PC. Once completed, the system may be left unattended for any length of time. The power should not be disconnected unless the system is being moved or put in long-term storage as the dissolved oxygen sensors will require lengthy repolarization after a power interruption.

### Chapter 3: Nomenclature

Table 4 lists the variables shown in the calculations of the different experiments.

Variables taken from instruments have the units they are recorded in noted.

Table 4. Nomenclature table. Variables are consistent across experiments. Only variables obtained from instruments will have recorded units.

Variable	Quantity	Calculation units	Recorded units
$A$	Total surface area of membrane	$m^2$	-
$A_w$	Wetted surface area	$m^2$	-
$C$	Dissolved oxygen concentration	mg/L	mg/L
$D$	Diameter	m	-
$d$	Diameter	m	-
$D_{OA}$	Diffusivity of oxygen in blood analog	$m^2/s$	-
$F$	Driving force	N	-
$f$	Fanning friction factor	(unitless)	-
$\mathfrak{F}$	Friction losses	$m^2/s^2$	-
$K$	Overall mass transfer coefficient	$m^3 \cdot s \cdot L / mol \cdot mg$	-
$k$	Specific mass transfer coefficient	$m^3 \cdot s \cdot L / mol \cdot mg$	-
$L$	Length	m	-
$\dot{m}$	Mass flowrate	mg/min	-
$N$	Molar flux	$mol/m^2 \cdot s$	-
$N_f$	Hollow fiber count	(unitless)	-
$P$	Pressure	Pa	mm Hg

Variable	Quantity	Calculation units	Recorded units
$p$	Membrane permeability	$\text{m}^3 \cdot \text{s} \cdot \text{L} / \text{mol} \cdot \text{mg}$	-
$Q$	Volumetric flowrate	L/min	GPM
$v$	Velocity	m/s	-
$y$	Volume fraction	(unitless)	%
$\varepsilon$	Void fraction	(unitless)	-
$\mu$	Viscosity (dynamic or absolute)	Pa·s	-
$\rho$	Density	$\text{kg}/\text{m}^3$	-
$Re$	Reynolds number	(unitless)	-
$Sc$	Schmidt number	(unitless)	-
$Sh$	Sherwood number	(unitless)	-

## Chapter 4: Mass transfer rate

During cardiopulmonary bypass, the blood oxygenator functions as a lung replacement. The natural lung contains a network of branching capillaries that single blood cells flow through. During natural breathing air enters from the nose and mouth, is humidified and adjusted to body temperature in the respiratory passages, and ultimately is received by the alveoli. Alveoli are thin-walled spherical membranes about 0.3 mm in diameter with a wall thickness of 1  $\mu\text{m}$ . These provide a surface area of about 80  $\text{m}^2$ . During one minute at resting conditions, approximately 250 mL of oxygen is transferred to the blood from the alveoli, and 200 mL of carbon dioxide diffuses from the blood to the lungs. In mildly hypothermic conditions, such as are used during CPB, an oxygenator must deliver 360 mg  $\text{O}_2/\text{min}$  to the bloodstream and remove about 370 mg  $\text{CO}_2/\text{min}$ . Not all carbon dioxide is removed; some must remain to prevent blood acidosis. Microporous hollow fiber membranes are used to provide the required permeability to oxygen and carbon dioxide [23].

In this experiment, the students measure the blood analog dissolved oxygen concentrations and flow rates to perform mass balances on the system. As an initial exposure to chemical engineering practice, safety is emphasized and potential hazards are identified for discussion. The students take redundant data measurements to verify the operation of the system by oxygen component balance.

Students conducting this laboratory will:

- Safely operate compressed gas cylinders and regulators.
- Measure gas and liquid flowrates using the rotameters.

- Measure dissolved oxygen concentration and oxygen in gas levels.
- Apply mass balances to independently determine the rate of oxygen exiting the gas stream, and the rate of oxygen entering the liquid stream.
- Identify the primary resistance to mass transfer from experimental data
- Explore design considerations of blood oxygenators from an engineering viewpoint.

Theory of the experiment, an outline of the procedure and a sample of the results are presented below. Detailed instructions for the laboratory are presented in Appendix Appendix A Raw pressure data for BA50 at 1 GPM.

#### **4.1 Background**

An oxygen balance around a single blood oxygenator unit is shown in Equation (1) and illustrated in Figure 7.

$$(\dot{m}_A + \dot{m}_1) - (\dot{m}_B + \dot{m}_2) = 0 \quad (1)$$



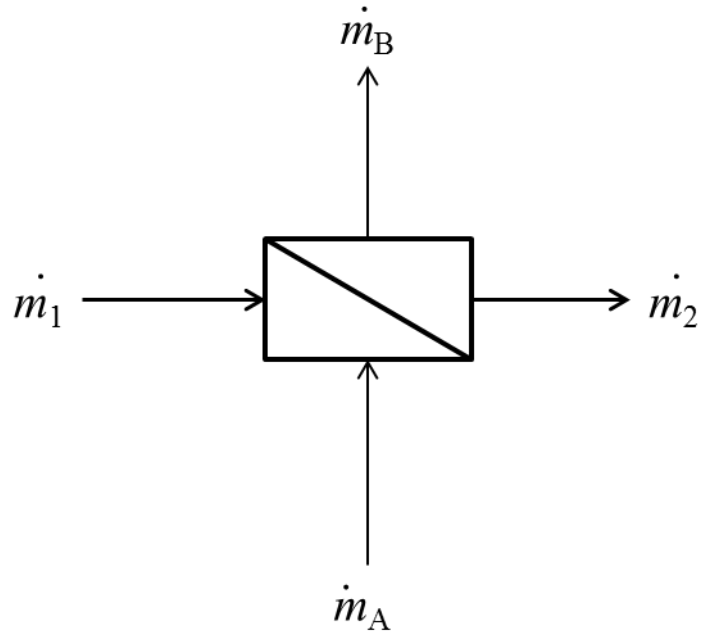

Figure 7. Oxygen mass flows entering and exiting a membrane unit. Horizontal and numbered streams (1 and 2) are liquid, vertical and lettered streams (A and B) are gas.

Expressing mass flowrate of oxygen in the liquid streams as the product of concentration and volumetric flowrate, and the mass flowrate of oxygen in the gas streams as the product of volumetric flowrate, volume fraction and density, we have:

$$Q_1 C_1 + Q_A y_A \rho_O = Q_2 C_2 + Q_B y_B \rho_O \quad (2)$$

where  $Q$  is the flowrate of blood analog liquid (L/min),  $C$  is the concentration of oxygen in the blood analog liquid (mg/L),  $y$  is the volume fraction of oxygen in the gas stream (1) and  $\rho$  is the density of oxygen gas at the experimental temperature and pressure (kg/L).

This assumes the density of the gas stream does not change. Rearranging terms to obtain liquid flowrates on one side of the equation and gas flowrates on the other:

$$Q_A y_A \rho_O - Q_B y_B \rho_O = Q_2 C_2 - Q_1 C_1 \quad (3)$$

Assuming that the changes in total volumetric flow of liquid and gas through the membrane unit are negligible, we can further factor terms. These assumptions are validated by the results presented in Section 4.3.

$$Q_G \rho_O (y_A - y_B) = Q_L (C_2 - C_1) \quad (4)$$

Each side of Equation (4) represents the mass flowrate of oxygen across the membrane. The location of the variables in the equation is shown in Figure 8.

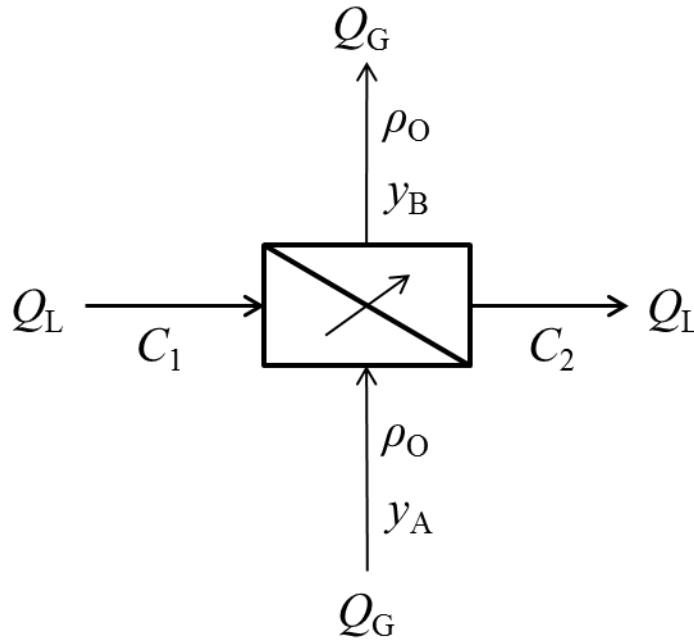

Figure 8. Blood oxygenator labeled with variables used in Equation (4). Central arrow indicates oxygen mass transfer across membrane, calculated using Equations (5) and (6).

Noting that each side of the equation represents a mass flow rate, we define a liquid side mass transfer rate:

$$\dot{m}_{\text{xfer}} = Q_L(C_2 - C_1) \quad (5)$$

and a gas side mass transfer rate:

$$\dot{m}_{\text{xfer}} = Q_G \rho_O (y_A - y_B) \quad (6)$$

where  $\dot{m}_{\text{xfer}}$  is the rate of mass transfer through the membrane (mg/min).

These two values of the mass transfer rate of oxygen across the membrane, which should be identical, are calculated by the students and compared. Differences that appear are to be explained by them in their final report. This introduces the concept of redundant measurements to the students.

## 4.2 Experimental procedure

Prior to the experiment, the freshmen are given an orientation covering safety and standard operating procedure for the system. After completion of the orientation, students are able to run the system with supervision.

The system is charged with BA100 blood analog (Table 1) as described in Section 2.2.1 and then started (Section 2.2.2). First the level of oxygen in the feed gas is determined using the method in Section 2.2.5. Once recorded, the flowrates of oxygen and blood analog are set to 1 SCFH and 3.8 L/min using the method outlined in Section 2.2.3.

Data are collected using the definitions of steady state and instruments listed in Sections 2.2.4 and 2.2.5. Once done, the system is cleaned and shut down (Section 2.2.7).

### 4.3 Sample results

The mean mass transfer rate is calculated as the average triplicate runs. An uncertainty analysis was performed using the Kline-McClintock propagation of error equation,

$$\Delta R = \pm \sqrt{\sum_{i=1}^n \left[ \frac{\partial R}{\partial x_i} \Delta x_i \right]^2} \quad (7)$$

where  $\Delta R$  is the uncertainty of a calculated value  $R$ .  $R$  is a function of  $n$  independent measurement variables  $x_1, x_2, x_3, \dots, x_n$ .  $\Delta x_i$  is the uncertainty associated with measuring variable  $x_i$ .

The uncertainties of each instrument are listed in Table 5.

Table 5. Uncertainties of instruments used in calculating the mass transfer rates out of the gas phase and into the liquid phase. The sample reading provided for the dissolved oxygen sensor is required to calculate the absolute uncertainty.

Instrument	Relative uncertainty	Sample reading	Absolute uncertainty
Liquid flowmeter	$\pm 4$ % full scale	-	0.53 L/min
Oxygen flowmeter	$\pm 6$ % full scale	-	0.12 L/min
Oxygen-in-gas meter	$\pm 1$ % full scale	-	1.00 (v/v)
Dissolved oxygen meter	$\pm 1$ % reading	13.2 mg/L	0.13 mg/L

Random error was found to be  $\pm 10.6$  mg oxygen/min on the liquid side (14.1 % of the mean value of 75 mg oxygen/min), and  $\pm 20.2$  mg oxygen/min on the gas side (29.8 % of the mean value of 68 mg oxygen/min). The larger random error on the gas side is caused by greater uncertainty in measuring gas flowrate and gas contents.

These averages, representing the liquid side mass transfer rate and the gas side mass transfer rate are compared using standard error in Figure 9.

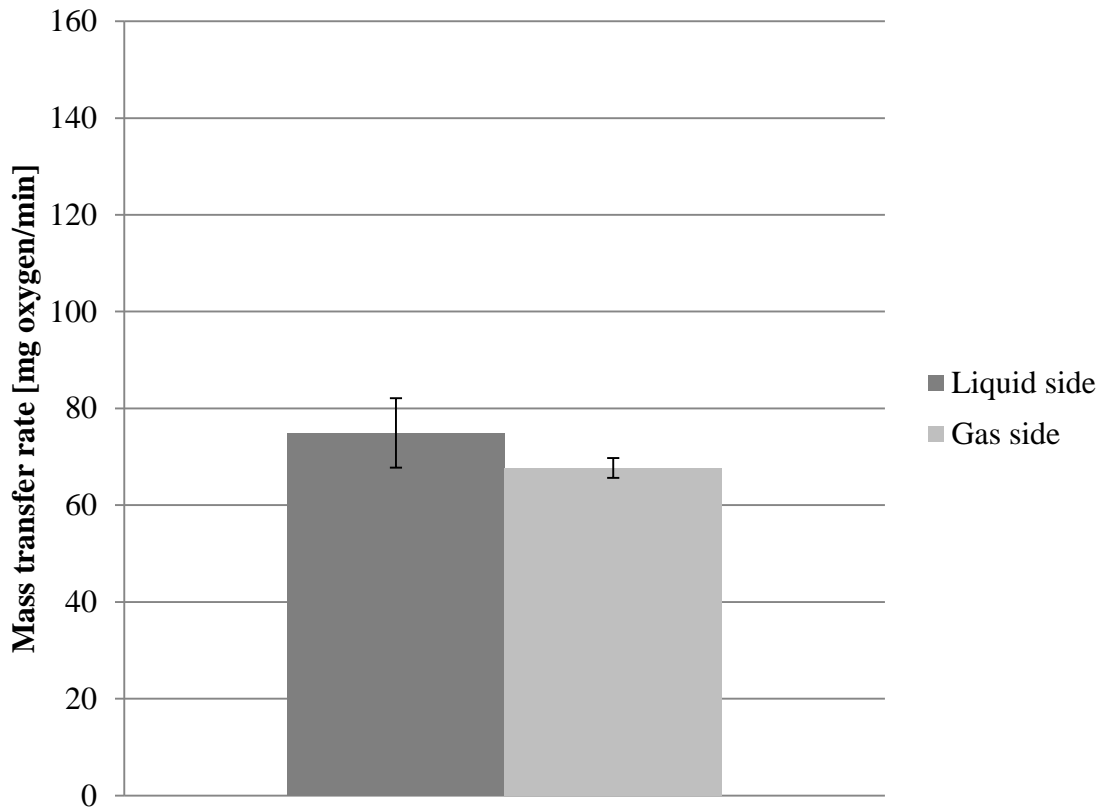

Figure 9. Standard error of the mean on the mass transfer rates across the membrane. Both values are an average of three data points. Students are expected to conclude that the mass transfer rates are statistically not different.

Since the standard error of the mean error bars overlap, with 95 % confidence, the calculated values of gas side and liquid side mass transfer rates are identical. When this experiment is conducted by freshmen, the uncertainty analysis is not performed.

The flowrates validate the assumption made in deriving Equation (4), that the rates of liquid and gas flow are constant through the membrane unit. By converting the

3.8 L/min of blood analog to a mass flowrate, we can then compare the flow rate of blood analog through the oxygenator to the rate of mass transfer across the membrane:

$$75 \frac{\text{mg}}{\text{min}} \ll 3.8 \frac{\text{kg}}{\text{min}} \quad (8)$$

By converting the 1 SCFH of oxygen supplied to the oxygenator to a mass flowrate, we have:

$$65 \frac{\text{mg}}{\text{min}} < 575 \frac{\text{mg}}{\text{min}} \quad (9)$$

These inequalities indicate that for each stream, the mass entering or exiting it may be considered negligible.

#### **4.3.1 Student learning**

This experiment was implemented in the Fall 2013 semester in one section of Rowan's Freshman Engineering Clinic. The experiment took approximately 1.5 hours for a team to complete. Each team of four students scheduled a block of time outside of class time to conduct the experiment. Students reviewed the lab handout prior to this time. Before beginning the experiment, the team met briefly with the professor and a teaching assistant to review the purpose of the experiment. The assistant then reviewed the operating procedure and safety precautions in detail with the students, who then conducted the experiment independently with the support of the assistant.

This section (4.3.1) is an assessment of learning outcomes as conducted and analyzed by the section professor, Stephanie Farrell [26]. To measure learning outcomes, a pretest and posttest were administered to two groups of students. One class section ( $n =$

23) served as the treatment group that performed the mass transfer experiment described here; two additional class sections ( $n = 41$ ) served as the control group that did not perform the experiment. All three course sections performed the same semester-long project during the course in which they designed, built and tested a simple model of a heart-lung machine in a challenge-based module. Class content and home assignments were coordinated among the three sections to be the same. Thus, the experiment described here was used to enhance the students' understanding of science and engineering concepts, data analysis, and engineering design as applied to a blood oxygenator beyond the understanding derived from participating in the project.

The pretest and posttest comprised eleven questions that target students' understanding related to (1) the application of mathematics, science and engineering principles, ABET A (2) designing and conducting experiments, analyzing and interpreting experimental data, ABET B and (3) designing a system or component to meet specific needs, ABET C. The pretest was administered in the second week of class before students began working on their semester-long project. The posttest was administered at the end of the semester, 3-4 weeks after the completion of the experiment and two weeks after completion of the project. The test questions were designed to address lower and higher levels of cognition [27]. Test questions were a mix of six multiple choice questions, four short verbal answer questions, and one mass balance question. The answers included distractors in addition to the correct answer. The test questions are provided in Appendix C Evaluation questions for experiment one.

Correct answers to multiple choice questions were awarded one point and incorrect answers were awarded zero points. Question 7 was an open response question;



its solution involved determination of the rate of mass transfer between phases. One point was awarded for mathematical representation of the three streams involved, one point for recognizing that the mass transfer rate was equivalent to the product of concentration and volumetric flow rate, and one point for applying the correct mathematical signs to indicate input or output terms. Question 8 asked for the three main functions of the heart-lung machine, and one point was awarded for each correct response. Question 9 asked why a very high blood flow rate should not be used to enhance mass transfer in a blood oxygenator, and one point was awarded if students identified a reasonable response directly or indirectly related to blood shear. Question 10 asked for a typical flow rate used in a blood oxygenator. The question was worth two points; one point was awarded for a response indicating a reasonable flowrate and one point for justification based on physiologic reasoning. Question 11 asked what body temperature is maintained during open heart surgery. The question was worth two points. One point was awarded for a correct answer indicating a temperature within a reasonable range, and one point was awarded for an explanation that was based on the body's demand for oxygen.

The two groups, treatment and control, were compared using unpaired, one-tailed Student *t*-tests at a 95% confidence level. In the two groups, there was no difference between the treatment and control based on average pretest scores ( $p = 0.3$ ).

Increases in knowledge between the pre- and post-tests were also assessed with unpaired, one-tailed Students *t*-tests at a 95% confidence level. In addition, the class average normalized gain was computed and used to evaluate knowledge gain as recommended by Hake [28]. The class average normalized gain is defined as the average actual gain divided by the maximum possible average gain:

$$CANG = \left( \frac{\text{Average pretest} - \text{average posttest}}{100 - \text{average pretest}} \right) \quad (10)$$

The posttest average for the treatment group was 79.12% (7.00%), and the posttest average for the control group was 55.58 (3.91%) where the number in parenthesis represents the 95% confidence interval. Thus there was a statistically significant difference between the treatment and control groups based on the average posttest score, with the treatment group outperforming the control group. **Figure 10** shows the average gain on each question of the posttest for the treatment group and for the control group, and Figure 11 shows the class average normalized gain for the two groups.

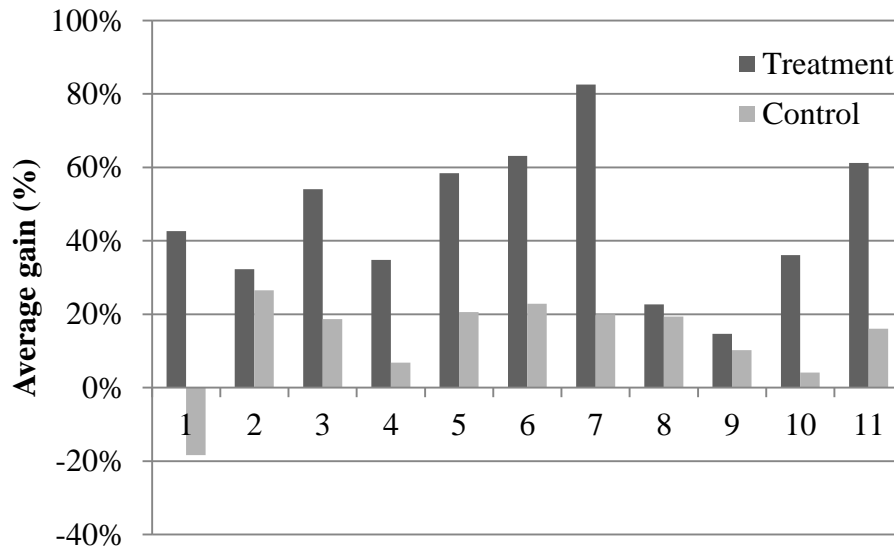

Figure 10. Average gains on assessment questions. The questions themselves are shown in Appendix C Evaluation questions for experiment one.

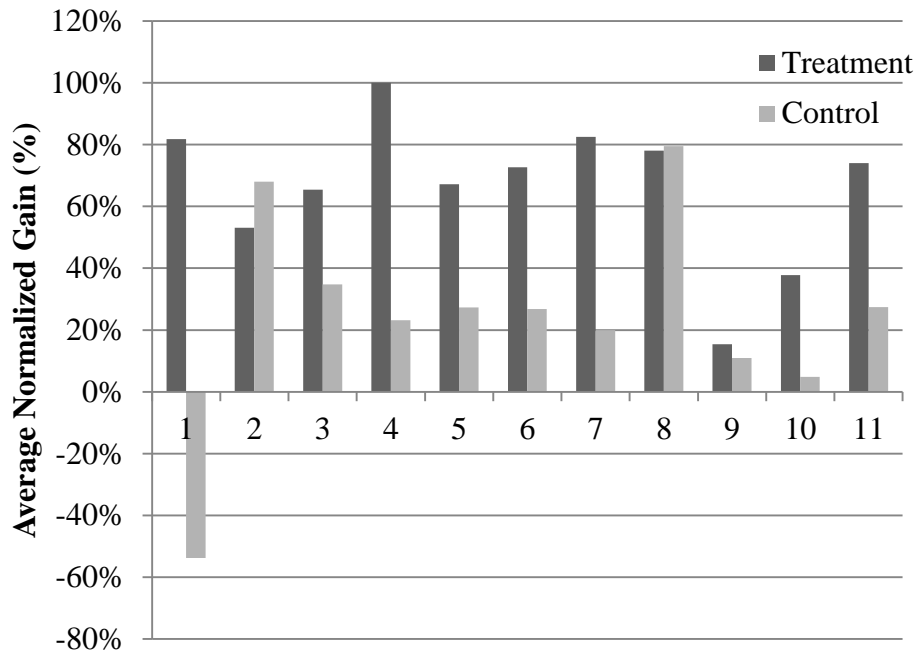

Figure 11. Class average normalized gain by question using Equation (7).

On almost every question, the gain and normalized gain were higher for the treatment group in comparison with the control group. The exceptions to this are the average normalized gain for questions 2 and 8, which asked about heart-lung machine function and operation. For these questions, the gain was higher for the treatment group, but the control group had a higher average normalized gain. However, heart-lung function and operation was mentioned briefly in the control sections prior to the administration of the pre-test, so the normalized gains are unreliable for questions 2 and 8. Hake [28] considers a high normalized gain to be 0.7 or higher. A medium normalized gain is defined as  $0.7 > g \geq 0.3$ , and a low normalized gain is below 0.3. The treatment group achieved high normalized gains on questions 1, 4, 6, 7, 8 and 11. Medium gains were achieved on questions 2, 3, 5 and 10. The negative gains shown by the control

group for question 1 may indicate a misconception that was developed through the project, and this will be explored independently when the project is repeated.

Since there was no significant difference between groups based on average pre-test scores, the effect size (Cohen's  $d$ ) was used evaluate the magnitude of differences between groups based on posttest scores. The calculated effect size of  $d = 4.05$  is well above the criterion for large effect size suggested by Cohen [29], indicating that the treatment had a large effect on student performance in the posttest.

## Chapter 5: Pressure drop

Pressure drop of blood in a blood oxygenator is potentially correlated to shear stress on the blood, which in turn causes blood trauma. Pressure drop is a function of the velocity of the flow through the unit, which for an incompressible fluid such as blood is directly proportional to the volumetric flowrate. For existing hollow fiber membranes pressure drops range from 5 kPa to at 2 L/min up to 37 kPa at 5 L/min [24]. Pressure drop is usually minimized by having the blood flow around hollow fibers while the oxygen is pumped through the fiber lumen [23].

In this experiment, students use the LabVIEW software program to record data from the pressure transducers located at the inlet and outlet of the oxygenator. Students analyze this data in spreadsheet software to determine the relationship between the friction factor and the Reynolds number of flow through the oxygenator.

Students conducting this laboratory will:

- Use the LabVIEW data collection software to record pressures of blood analog entering and exiting the blood oxygenator.
- Calculate friction factors and Reynolds numbers for blood analog flow from the pressure and flow rate measurements and physical properties.
- Compare calculated data to published results.

Theory of the experiment, an outline of the procedure and a sample of the results are presented below. Detailed instructions for the laboratory are presented in Appendix D Laboratory procedure for friction factor experiment.

## 5.1 Background

The Fanning friction factor is a dimensionless variable that is used to quantify the effect friction has on fluid pressure as it flows through a system. In a blood oxygenator it can be used to model the pressure drop at different flowrates of blood. Friction effects indicate shearing in the fluid, which damages the blood components [25].

Like all dimensionless quantities, the friction factor cannot be directly measured. It is instead calculated from measured quantities. Experimentally it has been found that frictional loss ( $\mathfrak{F}$ ) is a function of the inverse of the diameter of the pipe ( $D$ ), the velocity of the fluid ( $v$ ) raised to the second power, and the characteristic length ( $L$ ) [27]:

$$\mathfrak{F} \propto D^{-1}v^2L \quad (11)$$

To convert Equation (11) from proportionality to equation, we include a proportionality constant, the Fanning friction factor:

$$\mathfrak{F} = 2fv^2 \frac{L}{D} \quad (12)$$

For historical reasons, the Fanning friction factor ( $f$ ) is defined as one half of the value that would make Equation (11) an equality. There exists another very common friction factor called the Darcy-Weisbach friction factor, which is exactly four times the Fanning friction factor [27].

The friction factor is a function of the Reynolds number:

$$Re = \frac{Dv\rho}{\mu} \quad (13)$$

where  $D$  is the pipe diameter (m),  $v$  is the velocity (m/s),  $\rho$  is the fluid density ( $\text{kg/m}^3$ ) and  $\mu$  is the viscosity ( $\text{Pa}\cdot\text{s}$ ).

When the Reynolds number is less than 2100, the flow is laminar and the friction factor is a function of the Reynolds number alone. The oxygenator is not a simple pipe, but a woven mat of fibers in a cylindrical chamber. To calculate the Reynolds number, we must find an equivalent diameter and velocity. We use the method derived by Wickramasinghe et al [24]. First, the friction factor is defined in terms of the frictional force:

$$\mathfrak{F} = A_w(0.5\rho v^2)f \quad (14)$$

where  $\mathfrak{F}$  is the frictional force or drag on the fluid ( $\text{kg/m}\cdot\text{s}^2$ ),  $A_w$  is the wetted surface area ( $\text{m}^2$ ),  $\rho$  is the density of the fluid ( $\text{kg/m}^3$ ),  $v$  is the velocity of the fluid (m/s) and  $f$  is the Fanning friction factor.

The velocity through the fiber bundle, shown in Figure 12, is found [25] using:

$$\begin{aligned} v &= \frac{4(1 - \varepsilon)Q}{N_f \varepsilon \pi d_o^2} \\ &= \frac{4(1 - \varepsilon)Q}{\left(\frac{A}{\pi d_o L_f}\right) \varepsilon \pi d_o^2} \\ &= \frac{4(1 - \varepsilon)Q L_f}{A \varepsilon d_o} \end{aligned} \quad (15)$$

where  $N_f$  is the number of fibers in the oxygenator,  $A$  is the total membrane surface area ( $\text{m}^2$ ) and  $d_o$  the outside diameter of the individual fibers (m).

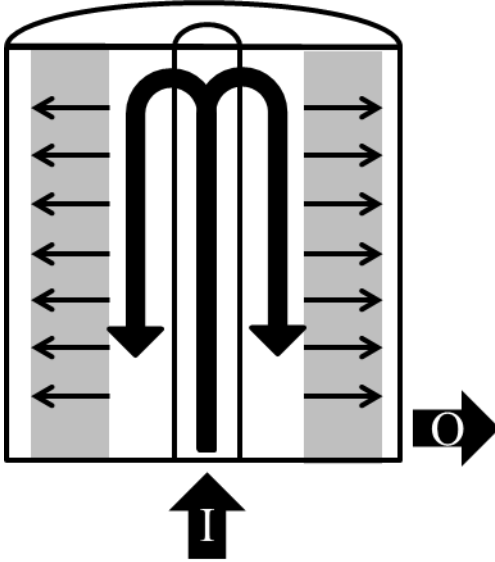

Figure 12. Medtronic Affinity NT fluid flows [24] in cutaway view. Blood from the heat exchanger (I) enters the central riser column and flows down the inner gap. The parallel arrows are the liquid flows through the woven hollow fiber mat, shown in gray. Their velocity is calculated using Equation (15). Oxygenated blood is collected at a side port (O).

For flow around cylindrical fibers we define a void fraction  $\varepsilon$ , which is the volume of space in the membrane containing chamber that the liquid can occupy, divided by the total volume of the chamber:

$$\varepsilon = \frac{\left(\frac{\pi}{4}\right) (D_o^2 - D_i^2) L_o - \left(\frac{\pi}{4}\right) d_o^2 L_f}{\left(\frac{\pi}{4}\right) (D_o^2 - D_i^2) L_o} \quad (16)$$



where  $D_o$  is the inside diameter of the membrane containing chamber,  $D_i$  is the outside diameter of the central riser the membrane mat is woven around,  $L_o$  is the length of the mass transfer chamber and  $L_f$  is the length of the fibers. All have units of length (m).

We also define an equivalent diameter:

$$d_e = \frac{4V_{\text{liquid}}}{A_w} = \frac{4\left(\frac{\pi}{4}\right)(D_o^2 - D_i^2)L_o}{\pi d_o L_f} = \frac{\varepsilon}{1 - \varepsilon} d_o \quad (17)$$

The driving force for liquid flow is:

$$F = \varepsilon \left(\frac{\pi}{4}\right) (D_o^2 - D_i^2) \Delta P \quad (18)$$

where  $\Delta P$  is the pressure drop in the liquid flowing through the oxygenator (Pa).

Combining Equations (14) through (18) we have:

$$\begin{aligned} f &= \frac{d_e \Delta P}{2L_o \rho} \left( \frac{A \varepsilon d_o}{4(1 - \varepsilon) Q L_f} \right)^2 \\ &= \frac{d_e}{2L_o} \left( \frac{A \varepsilon d_o}{4(1 - \varepsilon) L_f} \right)^2 \frac{\Delta P}{Q^2 \rho} \end{aligned} \quad (19)$$

In Equation (19) all variables on the right hand side of the equation are geometric, tabulated physical properties or directly measurable quantities. We use this equation to determine the friction factor for a range of flowrates of blood analog.

## 5.2 Experimental procedure

Pressure sensors located before and after the oxygenator are sampled by a data acquisition device (DAQ) which is connected by USB interface to a PC running LabVIEW software. Students are given an explanation of this and instructed on how to use the software to obtain data.

A blood analog from Table 1 is mixed and charged to the system holding tank as described in Section 2.2.1. The blood analogs are tested in a randomized order. Following this the system is started (Section 2.2.2). The flowrates of oxygen and blood analog are set to 1 SCFH and the blood analog flowrate is set to a value from Table 6 using the method outlined in Section 2.2.3.

Table 6. Liquid blood analog flowrates used in Experiment 2.

$Q$ [L/min]
2.3
2.6
3.0
3.4
3.8
4.2
4.5
4.9
5.3
5.7

Data are collected using the procedure in Section 2.2.6. After each flowrate has been tested three times, the blood analog solution is drained from the system (Section 2.2.7) and a new blood analog is mixed and charged, again using Section 2.2.2. This process repeats until all of the blood analog solutions have been tested in triplicate at the flowrates given above. This will take more than one day, so students will perform a shutdown and cleaning of the system (Section 2.2.7) before leaving the equipment.

### 5.3 Sample results

The analysis of a complete set of data is shown in Figure 13. As the Reynolds number increases, representing increasing velocity and density and decreasing viscosity, the friction factor decreases. This agrees with the theoretical development of the friction factor, which predicts a decrease in the friction factor as the Reynolds number increases if the flow is laminar. The maximum Reynolds number seen in this experiment is 11, which is much less than the critical Reynolds number for any geometry. Data from the manufacturer's publication is included.

A marked difference in slope (-0.89 v. -0.119) exists between the two data sets. Further research is needed to determine if the data from this experiment is incorrect, if the experiment is flawed, or if the manufacturer data is not directly comparable. It appears likely the experiment or the experimental data is incorrect; the manufacturer data strongly correlates with theoretical predictions.

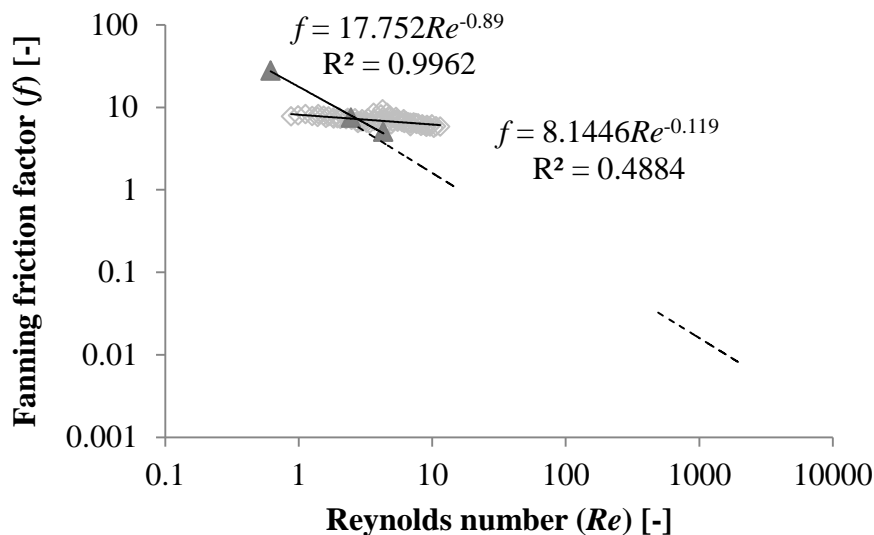

Figure 13. Friction factor of all blood analogs as a function of the Reynolds number (light gray diamonds) and the manufacturer's published data (solid dark triangles).

Manufacturer data does not indicate the source or properties of the fluid used in their tests. Dashed lines are  $f = 16/Re$  for flow through the fiber lumen (upper left) the empty mass transfer chamber (lower right), showing friction effects for flow through the fiber mat. Uncertainty analysis was not performed because the collected data is believed to be erroneous.

It is proposed that minor losses be investigated to determine if they are controlling the pressure drop at these flowrates. Metal fittings should be checked for burrs or irregularities and any angles in piping should be removed if possible. The sample port on top of the oxygenator unit (see Figure 12) should be investigated as a possible place to locate the outlet pressure transducer.

## Chapter 6: Mass transfer correlation

Dimensionless quantities are commonly used to report the complex relationships governing various phenomena of interest to chemical engineering. Mass transfer is commonly characterized with the Reynolds, Schmidt and Sherwood numbers. The Reynolds number is an indicator of the flow regime (laminar or turbulent). The Schmidt number ( $Sc$ ) is the ratio of viscous diffusivity to mass diffusivity ( $Sc = \mu/\rho D_{AB}$ ). The Sherwood number ( $Sh$ ) is the ratio of mass transfer by convection to mass transfer by diffusion ( $Sh = Kd_c/D_{AB}$ ) [30]. Correlations developed using these numbers show the interaction between the physical properties of the blood and operating parameters of the heart-lung machine in their effect on transfer of oxygen to the blood. This knowledge is important in designing new blood oxygenators and optimizing existing designs [28].

In this experiment students measure dissolved oxygen concentrations in the blood analog entering and exiting the oxygenator to determine the relationship between the Sherwood, Reynolds and Schmidt numbers. This correlation can then be used to describe the mass transfer characteristics under a wide range of operating conditions and fluid physical properties.

Students conducting this laboratory will:

- Calculate the Sherwood, Reynolds and Schmidt numbers from the dissolved oxygen concentration data and physical properties of the solutions.
- Transform the calculated values into a single correlation.
- Compare calculated data to published results.

Theory of the experiment, an outline of the procedure and a sample of the results are presented below. Detailed instructions for the laboratory are presented in Appendix E Laboratory procedure for mass transfer correlation experiment.

## 6.1 Background

We follow the method of analysis used by Wickramasinghe et al [26] in their experiments. The governing equation of mass transfer through the membrane is:

$$N = K \Delta C \quad (20)$$

where  $N$  is the total molar flux through the membrane,  $K$  is the overall mass transfer coefficient and  $\Delta C$  the concentration gradient across the membrane.

Mass transfer through the membrane requires the oxygen to overcome three resistances: the resistance of the gas side boundary layer ( $k_{\text{gas}}$ ), the resistance of the membrane itself ( $p_{\text{membrane}}$ ), and the resistance of the liquid side boundary layer ( $k_{\text{liquid}}$ ) [32].

$$K = \frac{1}{\frac{1}{k_{\text{liquid}}} + \frac{1}{p_{\text{membrane}}} + \frac{1}{k_{\text{gas}}}} \quad (21)$$

The gas is commercially pure oxygen supplied in excess, eliminating a concentration boundary layer on the gas side. The membrane is hydrophobic, which ensures the pores will be filled with oxygen. Experiments by Wickramasinghe et al [21] show that the mass transfer coefficient is dominated by the liquid side mass transfer coefficient, or:

$$K \cong \frac{1}{\frac{1}{k_{\text{liquid}}}} = k_{\text{liquid}} \quad (22)$$

The coefficient  $k_{\text{liquid}}$  may be related to measurable quantities by performing a mass balance on the oxygen in the liquid [33]:

$$0 = -Q \frac{dC}{dA} - k_{\text{liquid}}(C - C^*) \quad (23)$$

where  $Q$  is the volumetric flowrate of the liquid across the membrane (L/min),  $A$  is the membrane surface area ( $\text{m}^2$ ),  $C$  is the concentration of oxygen in the liquid (mg/L) and  $C^*$  is the concentration of oxygen in the liquid that would result from exposing the liquid to pure oxygen and allowing the two to come to equilibrium (mg/L).

Assuming the saturation concentration is constant at a constant temperature and pressure, we integrate and combine with Equation (22) to form:

$$K = \frac{Q}{A} \ln \left( \frac{C_0 - C^*}{C - C^*} \right) \quad (24)$$

where  $C_0$  is the concentration of solute in the liquid at the entrance to the membrane unit (mg/L) and  $C$  is the concentration of solute at the outlet (mg/L).

Using this coefficient, now we can define three dimensionless groups to describe mass transfer [31]:

$$Sh = \frac{K d_e}{D_{\text{OA}}} \quad (25)$$

where  $d_e$  is the equivalent diameter (m) and  $D_{\text{OA}}$  is the diffusivity of the oxygen solute through the analog solution ( $\text{m}^2/\text{s}$ ).

$$Re = \frac{d_e v \rho}{\mu} \quad (26)$$

where  $v$  is the velocity of the fluid across the membrane (m/s),  $\rho$  is the fluid density ( $\text{kg/m}^3$ ) and  $\mu$  is the fluid viscosity ( $\text{Pa}\cdot\text{s}$ ).

$$Sc = \frac{\mu}{\rho D_{OA}} \quad (27)$$

To form a single equation relating these three quantities, we use the form in Equation (28), which is based on the Chilton-Colburn J factor analysis [30] [34].

$$Sh = a Re^b Sc^{0.333} \quad (28)$$

## 6.2 Experimental procedure

Dissolved oxygen probes are located upstream and downstream of the oxygenator unit. These are automatically displayed on transmitters mounted on the panel front. A blood analog from Table 1 is mixed and charged to the system holding tank as described in Section 2.2.1. The blood analogs are not tested in a specific order. Following this the system is started (Section 2.2.2). The flowrates of oxygen and blood analog are set to 1 SCFH and the blood analog flowrate is set to a value from Table 6 using the method outlined in Section 2.2.3.

Table 7. Liquid blood analog flowrates used in Experiment 3.

$Q$ [L/min]
2.3
2.6
3.0
3.4
3.8



$Q$ [L/min]
4.2
4.5
4.9
5.3
5.7

Data are collected using the procedure in Section 2.2.6. After the above flowrates have had data recorded in triplicate, the blood analog solution is drained from the system (Section 2.2.7) and a new blood analog is mixed and charged, again using Section 2.2.2. This process repeats until all of the blood analog solutions have been tested in triplicate at the flowrates given above. This will take more than one day, so students will perform a shutdown and cleaning of the system (Section 2.2.7) before leaving the equipment.

### **6.3 Sample results**

The analysis of a complete set of data is shown in Figure 14 and compared to manufacturer data on the same make and model of oxygenator. The manufacturer's data correlation is obtained by converting the 100 % fraction of inspired oxygen ( $F_iO_2$ ) mass transfer data from the published information [24]. This information did not provide any information on the blood analog fluid, so it was assumed to be healthy human blood at hypothermic operating conditions (27 °C). Final dissolved oxygen concentration was modeled on the saturation measurements of BA50: At 1 L/min the BA50 analog was approximately 84 % of saturation. Similarly at 4 L/min, 77 % was observed and at 7 L/min, 70 %.

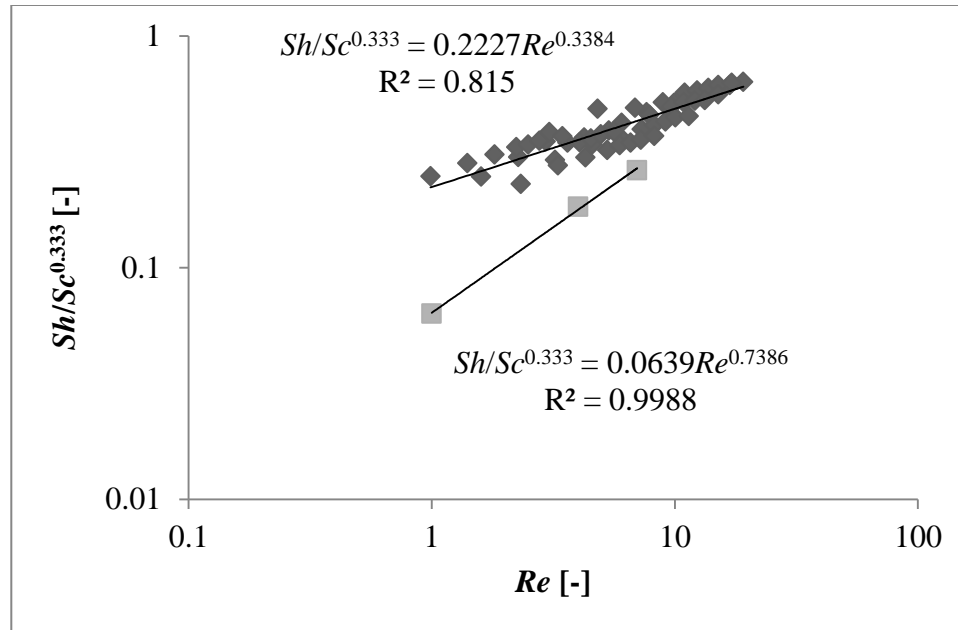

Figure 14. Correlations between Sherwood, Schmidt and Reynolds numbers showing mass transfer in the Medtronic Affinity NT oxygenator. Diamonds represent new data from this experiment. Squares show adaptation of manufacturer's mass transfer data. The root mean square (RMS) error of the correlation is 0.0478 and the bias is -0.00291.

Saturation concentration of oxygen in blood was obtained by calculating the density of oxygen using the ideal gas law at 101,325 Pa and 27 °C and multiplying by the hemoglobin carrying capacity of oxygen, 0.167 mL O<sub>2</sub>/mL blood [39].

## Chapter 7: Summary

Chemical engineering is of growing importance to medicine and medical technology. It is the responsibility of college engineering programs to keep their curriculum offerings relevant to students who will enter the workforce. Using biomedical-focused laboratory experiments allows integration of medical topics into existing programs and courses. Laboratories and associated learning materials for teaching mass balancing, fluid flow and mass transfer have been developed around a clinical blood oxygenator from a heart-lung machine. These are suitable for inclusion in courses on introductory chemical engineering principles, fluid mechanics, mass transport and unit operations. Effect of these experiments on student learning has not been studied, but is left for future investigations.

Mass transfer of oxygen through the hollow fiber membranes was found to be approximately 70 mg/min at 1 L/min blood analog flow and 1 SCFH oxygen supplied. Uncertainty analysis combined with statistical analysis shows that the mass transfer rate of oxygen leaving the gas stream and the mass transfer rate of oxygen entering the liquid stream may or may not be the same. Further work is required to reduce the uncertainty and spread of data for a definitive conclusion.

Data taken to test the pressure drop experiment's validity does not agree with manufacturer data or literature predictions for pressure drop: A correlation between the Fanning friction factor and Reynolds number was found to be  $f = 8.1/Re^{0.12}$  compared to  $f = 17/Re^{0.89}$  for manufacturer data and laminar flow theory of  $f = 16/Re$ . It is suspected the experimental system contains permanent frictional losses which are responsible and

further work is required to improve the results. All data was collected in triplicate with randomization to reduce random errors.

A mass transfer correlation of  $Sh/Sc^{0.333} = 0.223Re^{0.338}$  was obtained for a range of blood analog liquids. Manufacturer data for this particular model of oxygenator was transformed to allow direct comparison and provides a correlation of  $Sh/Sc^{0.333} = 0.0639Re^{0.7386}$ .

## List of references

- [1] National Research Council (US), "Accomplishments and Challenges in Health and Medicine for Chemistry and Chemical Engineering," in *Health and Medicine: Challenges for the Chemical Sciences in the 21st Century*, Washington, DC, National Academies Press (US), 2004.
- [2] S. B. Campbell and T. Hoare, "Externally addressable hydrogel nanocomposites for biomedical applications," *Current Opinion in Chemical Engineering*, vol. 4, pp. 1-10, 2014.
- [3] I. D. L. Bogle, "Recent developments in Process Systems Engineering as applied to medicine," *Current Opinion in Chemical Engineering*, vol. 1, no. 4, pp. 453-458, 2012.
- [4] M. Kawahara and T. Nagamune, "Engineering of mammalian cell membrane proteins," *Current Opinion in Chemical Engineering*, vol. 1, no. 4, pp. 411-417, 2012.
- [5] P. Bartolo, J.-P. Kruth, J. Silva, G. Levy, A. Malshe, K. Rajurkar, M. Mitsuishi, J. Ciurana and M. Leu, "Biomedical production of implants by additive electro-chemical and physical processes," *CIRP Annals - Manufacturing Technology*, vol. 61, no. 2, pp. 635-655, 2012.
- [6] American Institute of Chemical Engineers, "Chemical Engineers in the Biomedical Field: From Discoveries to Solutions," AIChE, 2009.
- [7] Bureau of Labor Statistics, "Employment Projections: Employment by detailed occupation," United States Department of Labor, Washington, DC, 2013.
- [8] D. C. Shallcross, "Career Preferences for Undergraduate Chemical Engineering Students: Results of an International Survey," *Education for Chemical Engineers*, vol. 1, no. 1, pp. 30-38, 2006.
- [9] K. A. Hollar, S. H. Farrell, G. B. Hecht and P. Mosto, "Integrating Biology and ChE at the Lower Levels," *Chemical Engineering Education*, vol. 38, no. 2, pp. 108-113, 2004.

- [10] R. S. Parker, F. J. Doyle and M. A. Henson, "Integrating Biological Systems in the Process Dynamics and Control Curriculum," *Chemical Engineering Education*, vol. 40, no. 3, pp. 181-188, 2006.
- [11] S. Carson, J. R. Chisnell and R. M. Kelly, "Integrating Modern Biology Into the ChE Biomolecular Engineering Concentration Through a Campuswide Core Laboratory Education Program," *Chemical Engineering Education*, vol. 43, no. 4, pp. 257-264, 2009.
- [12] ABET, "Criteria for Accrediting Engineering Programs, 2014 - 2015," 26 October 2013. [Online]. Available:  
[http://www.abet.org/uploadedFiles/Accreditation/Accreditation\\_Step\\_by\\_Step/Accreditation\\_Documents/Current/2014\\_-\\_2015/E001%2014-15%20EAC%20Criteria%203-13-14\(2\).pdf](http://www.abet.org/uploadedFiles/Accreditation/Accreditation_Step_by_Step/Accreditation_Documents/Current/2014_-_2015/E001%2014-15%20EAC%20Criteria%203-13-14(2).pdf). [Accessed 27 May 2014].
- [13] Engineers Australia, "Program Accreditation," [Online]. Available:  
[http://www.engineersaustralia.org.au/sites/default/files/shado/Education/Program%20Accreditation/140203\\_foreword\\_to\\_stage\\_1\\_standards.pdf](http://www.engineersaustralia.org.au/sites/default/files/shado/Education/Program%20Accreditation/140203_foreword_to_stage_1_standards.pdf). [Accessed 27 May 2014].
- [14] Institution of Chemical Engineers, "Accreditation," [Online]. Available:  
[http://www.icheme.org/membership/~/\\_media/Documents/icheme/Membership/Accreditation/accreditationguide0212.pdf](http://www.icheme.org/membership/~/_media/Documents/icheme/Membership/Accreditation/accreditationguide0212.pdf). [Accessed 27 May 2014].
- [15] R. M. Felder, D. R. Woods, J. E. Stice and A. Rugarcia, "The Future of Engineering Education: Part 2. Teaching Methods that Work," *Chemical Engineering Education*, vol. 34, no. 1, pp. 26-39, 2000.
- [16] M. Long, A Hands-On Approach To Calculus (EdD dissertation), Morgantown, West Virginia: University of West Virginia, 2004.
- [17] H. E. Pacella, H. J. Eash, B. J. Frankowski and W. J. Federspiel, "Darcy permeability of hollow fiber bundles used in blood oxygenation devices," *Journal of Membrane Science*, vol. 382, no. 1-2, pp. 238-242, 2011.
- [18] F. De Somer, L. Foubert, M. Vanackere, D. Dujardin, J. Delanghe and G. V. Nooten, "Impact of oxygenator design on hemolysis, shear stress, and white blood cell and platelet counts," *Journal of Cardiothoracic and Vascular Anesthesia*, vol. 10, no. 7, pp. 884-889, 1996.

- [19] A. A. Piplani, A. Makarewicz, J.-P. Dueri and T. A. Afzal, "Integrated blood oxygenator and pump system having means for reducing fiber breakage". United States Patent 6224829 B1, 1 May 2001.
- [20] J. A. Wegner, "Oxygenator anatomy and function," *Journal of Cardiothoracic and Vascular Anesthesia*, vol. 11, no. 3, pp. 275-281, 1997.
- [21] J. Zhang, T. D. Nolan, T. Zhang, B. P. Griffith and Z. J. Wu, "Characterization of membrane blood oxygenation devices using computational fluid dynamics," *Journal of Membrane Science*, vol. 288, no. 1-2, pp. 268-279, 2007.
- [22] W. S. Haworth, "The Development of the Modern Oxygenator," *The Annals of Thoracic Surgery*, vol. 76, no. 6, pp. S2216-S2219, 2003.
- [23] S. Wickramasinghe, J. Garcia and B. Han, "Mass and momentum transfer in hollow fibre blood oxygenators," *Journal of Membrane Science*, vol. 208, no. 1-2, pp. 247-256, 2002.
- [24] Medtronic, Inc., "Affinity NT Oxygenation System," 5 April 2011. [Online]. Available: <http://www.medtronic.com/for-healthcare-professionals/products-therapies/cardiovascular/cardiopulmonary-products/affinity-nt-cardiotomy-venous-reservoir/index.htm>. [Accessed 23 April 2014].
- [25] D. F. Stamatialis, B. J. Papenburg, M. Girones, S. Saiful, S. N. Bettahalli, S. Schmitmeier and M. Wessling, "Medical applications of membranes: Drug delivery, artificial organs and tissue engineering," *Journal of Membrane Science*, vol. 308, no. 1-2, pp. 1-34, 2008.
- [26] S. Farrell, Interviewee, *Personal communication (Email)*. [Interview]. 28 July 2014.
- [27] L. W. Anderson and D. R. Krathwohl, *A Taxonomy for Learning, Teaching and Assessing: A Revision of Bloom's Taxonomy*, New York: Longman Publishing, 2001.
- [28] R. R. Hake, "Interactive-engagement vs Traditional Methods: A Six-thousand-student Survey of Mechanics Test Data for Introductory Physics Courses," *American Journal of Physics*, vol. 66, no. 1, pp. 64-74, 1998.
- [29] J. Cohen, *Statistical power analysis for the behavioral sciences*, Hillsdale, NJ: L. Erlbaum Associates, 1988.

- [30] M. Grigioni, C. Daniele, G. D'Avenio and V. Barbaro, "Evaluation of the surface-averaged load exerted on a blood element by the Reynolds shear stress field provided by artificial cardiovascular devices," *Journal of Biomechanics*, vol. 35, no. 12, pp. 1613-1622, 2002.
- [31] N. de Nevers, "Turbulent Flow," in *Fluid Mechanics for Chemical Engineers*, McGraw-Hill, 2005, pp. 183-188.
- [32] S. R. Wickramasinghe and B. Han, "Mass and momentum transfer in commercial blood oxygenators," *Desalination*, vol. 148, no. 1-3, pp. 227-233, 2002.
- [33] R. L. Fournier, "6.6.5 Solute Transfer," in *Basic Transport Phenomena In Biomedical Engineering*, CRC Press, 1998, pp. 158-162.
- [34] C. J. Geankoplis, "Dimensionless Numbers Used to Correlate Data," in *Transport Processes and Separations Process Principles*, Pearson Prentice Hall, 2003, pp. 473-474.
- [35] S. R. Wickramasinghe, C. M. Kahr and B. Han, "Mass Transfer in Blood Oxygenators Using Blood Analogue Fluids," *Biotechnology Progress*, vol. 18, no. 4, pp. 867-873, 2002.
- [36] C. J. Geankoplis, "Series Resistances in Membrane Processes," in *Transport Processes and Separations Process Principles*, Pearson Prentice Hall, 2003, pp. 841-843.
- [37] S. Wickramasinghe, M. J. Semmens and E. Cussler, "Hollow fiber modules made with hollow fiber fabric," *Journal of Membrane Science*, vol. 84, no. 1-2, pp. 1-14, 1993.
- [38] T. H. Chilton and A. P. Colburn, "Mass Transfer (Absorption) Coefficients," *Industrial and Engineering Chemistry*, vol. 26, no. 11, pp. 1183-1187, 1934.
- [39] T. J. Hewitt, B. G. Hattler and W. J. Federspiel, "A Mathematical Model of Gas Exchange in an Intravenous Membrane Oxygenator," *Annals of Biomedical Engineering*, vol. 26, no. 1, pp. 166-178, 1998.



### Appendix A Raw pressure data for BA50 at 1 GPM

mmHg BPin	mmHg BPout	mmHg deltaBP	mmHg O2in	mmHg O2out	mmHg deltaO2	Untitled
129.4526	77.78723	51.66533	7.298974	-0.69888	7.997856	0
140.858	86.34217	54.51581	7.166504	-0.56781	7.734313	0
137.7117	88.26537	49.44629	7.232739	-0.56781	7.800547	0.021001
124.6675	85.67899	38.98853	7.431443	-0.50227	7.933714	0.043002
96.15396	74.07346	22.0805	7.232739	-0.56781	7.800547	0.066004
69.5413	50.39817	19.14313	7.10027	-0.69888	7.799152	0.088005
60.49562	30.70191	29.7937	7.034035	-0.76442	7.798455	0.110006
52.43316	29.97242	22.46074	7.166504	-0.56781	7.734313	0.132008
50.46671	34.81359	15.65312	7.10027	-0.69888	7.799152	0.154009
56.03833	35.67572	20.36261	7.431443	-0.43673	7.868177	0.17601
67.83704	39.25685	28.58019	7.298974	-0.56781	7.866782	0.198011
82.78208	49.0055	33.77658	7.166504	-0.69888	7.865387	0.220012
98.97254	60.74367	38.22887	7.232739	-0.56781	7.800547	0.242014
113.1965	70.62496	42.57159	7.10027	-0.69888	7.799152	0.264015
124.4709	76.26193	48.20894	7.10027	-0.69888	7.799152	0.286016
131.7467	78.78199	52.96476	7.232739	-0.56781	7.800547	0.308018
135.6141	79.5778	56.03631	7.365209	-0.43673	7.801943	0.330019
137.6461	79.77675	57.86936	7.298974	-0.50227	7.801245	0.35202
138.1049	80.37361	57.73134	7.10027	-0.50227	7.602541	0.374021
139.6781	82.42944	57.24867	7.166504	-0.69888	7.865387	0.396022
140.2025	84.68423	55.51826	7.298974	-0.63335	7.932319	0.418024
134.3687	87.27061	47.09808	7.298974	-0.63335	7.932319	0.450026
116.8673	82.89367	33.97359	7.10027	-0.69888	7.799152	0.472027
86.1906	67.37541	18.81519	7.298974	-0.43673	7.735708	0.494028
64.42852	41.11374	23.31479	7.232739	-0.63335	7.866085	0.516029
57.61149	28.04922	29.56227	7.431443	-0.43673	7.868177	0.539031
50.53226	32.02826	18.504	7.365209	-0.43673	7.801943	0.561032
51.58103	35.21149	16.36954	7.10027	-0.69888	7.799152	0.583033
59.18465	36.0073	23.17735	7.365209	-0.43673	7.801943	0.605034
72.22879	42.17482	30.05397	7.166504	-0.76442	7.930924	0.627036
87.82931	53.05086	34.77845	7.232739	-0.56781	7.800547	0.649037
103.3643	64.39113	38.97316	7.431443	-0.43673	7.868177	0.671038
116.5395	72.41552	44.12399	7.10027	-0.69888	7.799152	0.693039
126.8306	76.9251	49.90551	7.232739	-0.56781	7.800547	0.715041
132.9266	78.91462	54.012	7.232739	-0.56781	7.800547	0.737042
136.3351	79.71043	56.62471	7.298974	-0.56781	7.866782	0.759043
137.7772	79.84307	57.93414	7.431443	-0.43673	7.868177	0.781044
138.826	80.97046	57.85552	7.298974	-0.50227	7.801245	0.803046
139.8748	83.09262	56.78214	7.298974	-0.63335	7.932319	0.825047
138.6293	85.34741	53.28193	7.232739	-0.56781	7.800547	0.848048

133.3199	86.0769	47.24301	7.232739	-0.56781	7.800547	0.870049
117.0639	81.96522	35.09868	7.298974	-0.56781	7.866782	0.892051
88.28815	67.64068	20.64747	7.232739	-0.56781	7.800547	0.914052
65.93614	44.0317	21.90444	7.497678	-0.43673	7.934412	0.936053
58.85691	29.30925	29.54766	7.232739	-0.50227	7.73501	0.958055
51.77768	32.49248	19.2852	7.166504	-0.50227	7.668776	0.981056
52.03987	35.67572	16.36416	7.034035	-0.69888	7.732918	1.003057
58.98801	36.60416	22.38385	7.298974	-0.43673	7.735708	1.025058
70.98337	41.37901	29.60436	7.232739	-0.43673	7.669473	1.04706
85.60066	51.59188	34.00878	7.232739	-0.50227	7.73501	1.069061
102.25	63.1311	39.11887	7.298974	-0.43673	7.735708	1.092062
115.2941	71.22181	44.07228	7.365209	-0.50227	7.86748	1.115064
125.3886	75.79771	49.59084	7.298974	-0.63335	7.932319	1.137065
131.6812	78.18513	53.49607	7.298974	-0.56781	7.866782	1.158066
135.5486	79.17989	56.36866	7.232739	-0.56781	7.800547	1.180067
137.8428	79.84307	57.99969	7.365209	-0.43673	7.801943	1.202069
139.2193	81.56732	57.65195	7.166504	-0.50227	7.668776	1.22407
140.3991	83.49052	56.90862	7.298974	-0.56781	7.866782	1.246071
141.2513	86.34217	54.9091	7.034035	-0.69888	7.732918	1.268073
136.0074	87.66851	48.33888	7.232739	-0.43673	7.669473	1.290073
120.8657	84.15369	36.71202	7.298974	-0.56781	7.866782	1.312075
91.30338	70.0281	21.27528	7.298974	-0.43673	7.735708	1.334076
67.31265	46.28649	21.02616	6.9678	-0.69888	7.666683	1.356077
60.03678	29.44189	30.59489	7.166504	-0.56781	7.734313	1.378078
52.23652	31.49772	20.7388	7.166504	-0.56781	7.734313	1.40008
51.58103	35.54308	16.03795	7.10027	-0.69888	7.799152	1.422081
58.20142	36.33889	21.86254	7.232739	-0.56781	7.800547	1.444082
69.86904	40.78215	29.08689	7.298974	-0.50227	7.801245	1.466084
84.42079	50.72975	33.69104	7.365209	-0.43673	7.801943	1.488085
99.82467	61.93738	37.88729	7.10027	-0.69888	7.799152	1.510086
113.3932	70.35969	43.03351	7.232739	-0.50227	7.73501	1.532087
125.1919	75.86403	49.32788	7.298974	-0.56781	7.866782	1.556089
131.8123	78.64936	53.16294	7.298974	-0.56781	7.866782	1.57809
135.7452	79.51148	56.23372	7.232739	-0.56781	7.800547	1.601091
137.8428	79.84307	57.99969	7.034035	-0.69888	7.732918	1.623093
139.0882	81.30205	57.78612	7.10027	-0.69888	7.799152	1.645094
140.3336	83.4242	56.90939	7.232739	-0.56781	7.800547	1.667095
140.6613	85.87795	54.78339	7.232739	-0.63335	7.866085	1.689096
137.9738	88.26537	49.70848	7.034035	-0.69888	7.732918	1.711098
124.9953	86.20953	38.78573	7.365209	-0.3712	7.736405	1.733099
96.54725	74.40505	22.1422	6.9678	-0.69888	7.666683	1.7551
69.4102	50.33185	19.07836	7.232739	-0.69888	7.931622	1.777102
60.49562	30.10506	30.39056	7.365209	-0.43673	7.801943	1.799103

52.62981	30.23769	22.39212	7.232739	-0.56781	7.800547	1.821104
50.59781	34.61464	15.98317	7.298974	-0.56781	7.866782	1.843105
56.16942	35.87467	20.29476	7.10027	-0.76442	7.864689	1.865107
67.83704	39.38949	28.44755	7.431443	-0.43673	7.868177	1.887108
82.65098	49.40341	33.24758	7.232739	-0.50227	7.73501	1.909109
98.71035	61.00894	37.70141	7.365209	-0.56781	7.933017	1.93111
112.6722	70.29337	42.37879	7.166504	-0.69888	7.865387	1.953112
123.6843	75.53244	48.15185	7.232739	-0.50227	7.73501	1.975113
131.4846	78.84831	52.63625	7.166504	-0.56781	7.734313	1.997114
135.483	79.90938	55.57363	7.365209	-0.43673	7.801943	2.019115
137.7117	80.24097	57.47068	7.232739	-0.63335	7.866085	2.041117
138.8915	81.03678	57.85475	7.431443	-0.43673	7.868177	2.066118
140.1369	82.95998	57.17697	7.431443	-0.43673	7.868177	2.08812
140.9891	85.81163	55.17745	7.232739	-0.56781	7.800547	2.11012
138.1049	88.398	49.70694	7.232739	-0.50227	7.73501	2.132122
126.5684	86.40848	40.15994	7.298974	-0.43673	7.735708	2.154123
98.84144	75.59876	23.24269	7.365209	-0.3712	7.736405	2.176124
70.52453	51.92347	18.60106	7.166504	-0.50227	7.668776	2.198125
60.95446	30.90087	30.05359	7.166504	-0.76442	7.930924	2.220127
53.0231	29.37557	23.64753	7.431443	-0.56781	7.999252	2.242128
50.07342	34.41569	15.65773	7.232739	-0.56781	7.800547	2.264129
55.31729	35.21149	20.1058	7.298974	-0.63335	7.932319	2.28613
66.98491	38.72631	28.2586	7.298974	-0.43673	7.735708	2.308132
81.8644	48.40865	33.45576	7.232739	-0.56781	7.800547	2.330133
98.25151	60.41209	37.83942	7.298974	-0.43673	7.735708	2.352134
112.6722	70.29337	42.37879	7.232739	-0.43673	7.669473	2.374135
124.1431	76.06298	48.08015	7.431443	-0.43673	7.868177	2.396137
131.8123	78.98094	52.83136	7.166504	-0.76442	7.930924	2.418138
135.6797	79.77675	55.90291	7.232739	-0.56781	7.800547	2.440139
137.7117	80.04202	57.66964	7.10027	-0.76442	7.864689	2.462141
138.5638	80.57256	57.99123	7.10027	-0.69888	7.799152	2.484142
139.547	81.96522	57.58179	7.232739	-0.56781	7.800547	2.506143
140.2025	85.01582	55.18668	7.166504	-0.69888	7.865387	2.528144
137.5806	86.74007	50.84049	7.10027	-0.76442	7.864689	2.550146
125.7163	84.9495	40.76679	7.10027	-0.56781	7.668078	2.574147
98.05486	74.40505	23.64982	7.166504	-0.76442	7.930924	2.597148
70.13124	50.66344	19.4678	7.232739	-0.56781	7.800547	2.61915
60.82336	30.76823	30.05513	7.431443	-0.3712	7.80264	2.642151
53.1542	30.23769	22.9165	7.10027	-0.69888	7.799152	2.664152
50.86	34.68096	16.17905	7.034035	-0.69888	7.732918	2.686153
56.03833	35.41045	20.62788	7.10027	-0.63335	7.733615	2.708155
66.72272	38.66	28.06272	7.431443	-0.43673	7.868177	2.730156
80.94673	48.14338	32.80335	7.232739	-0.56781	7.800547	2.752157

97.00609	59.35101	37.65508	7.034035	-0.76442	7.798455	2.774158
111.0334	68.56912	42.46433	7.298974	-0.56781	7.866782	2.79616
122.7666	75.0019	47.76472	7.232739	-0.50227	7.73501	2.818161
130.698	78.11882	52.57916	7.232739	-0.50227	7.73501	2.840162
135.1553	79.77675	55.37852	7.232739	-0.56781	7.800547	2.862164
137.7772	80.30729	57.46992	7.232739	-0.56781	7.800547	2.884165
139.0882	81.16941	57.91876	7.232739	-0.63335	7.866085	2.906166
139.7437	82.69471	57.04894	7.431443	-0.3712	7.80264	2.928167
140.6613	84.81687	55.84447	7.232739	-0.56781	7.800547	2.950169
138.8915	87.13798	51.75355	7.166504	-0.76442	7.930924	2.97217
129.7147	86.20953	43.50522	7.232739	-0.56781	7.800547	2.994171
104.282	77.45564	26.82632	7.10027	-0.69888	7.799152	3.016172
73.80195	56.69831	17.10363	7.034035	-0.76442	7.798455	3.039174
61.21665	32.9567	28.25995	7.431443	-0.43673	7.868177	3.061175
54.00633	28.57976	25.42657	7.431443	-0.43673	7.868177	3.084176
49.87677	33.75251	16.12426	7.298974	-0.56781	7.866782	3.106177
59.05355	36.20625	22.8473	7.298974	-0.43673	7.735708	3.139179
71.96659	41.64428	30.32232	7.166504	-0.82996	7.996461	3.162181
87.30492	52.52032	34.7846	7.365209	-0.50227	7.86748	3.184182
102.9054	63.72795	39.17749	7.298974	-0.43673	7.735708	3.206183
115.884	71.68603	44.198	7.298974	-0.56781	7.866782	3.228185
126.2407	76.39457	49.84612	7.431443	-0.43673	7.868177	3.250185
132.4678	78.4504	54.01738	7.298974	-0.63335	7.932319	3.272187
135.6141	79.17989	56.43421	7.232739	-0.56781	7.800547	3.294188
137.8428	79.51148	58.33127	7.232739	-0.56781	7.800547	3.316189
139.0226	81.16941	57.85321	7.166504	-0.69888	7.865387	3.338191
140.5302	83.49052	57.03972	7.10027	-0.69888	7.799152	3.360192
140.268	86.14321	54.12483	7.298974	-0.43673	7.735708	3.382193
135.0897	87.20429	47.88543	7.232739	-0.50227	7.73501	3.404195
118.9648	83.55684	35.40797	7.232739	-0.56781	7.800547	3.426196
88.81254	68.5028	20.30973	7.232739	-0.69888	7.931622	3.448197
66.19833	43.89907	22.29927	7.232739	-0.43673	7.669473	3.470198
59.3813	28.64608	30.73522	7.166504	-0.69888	7.865387	3.492199
51.64658	32.02826	19.61832	7.298974	-0.43673	7.735708	3.514201
51.51549	35.41045	16.10504	7.298974	-0.56781	7.866782	3.536202
58.33252	36.27257	22.05995	7.431443	-0.3712	7.80264	3.558203
70.72117	41.18006	29.54112	7.232739	-0.56781	7.800547	3.581205
86.1906	52.25505	33.93555	7.298974	-0.50227	7.801245	3.604206
101.8567	63.1311	38.72557	7.298974	-0.50227	7.801245	3.626207
114.8353	70.82391	44.01135	7.431443	-0.50227	7.933714	3.649209
124.9297	75.53244	49.39727	7.431443	-0.43673	7.868177	3.67121
131.8123	78.18513	53.62716	7.232739	-0.56781	7.800547	3.693211
135.5486	79.04726	56.5013	7.034035	-0.76442	7.798455	3.715212

137.9738	80.04202	57.93183	7.232739	-0.63335	7.866085	3.737214
139.2193	81.23573	57.98354	7.034035	-0.89549	7.929529	3.759215
140.9891	83.62316	57.36592	7.298974	-0.50227	7.801245	3.781216
141.4479	86.60744	54.84048	7.10027	-0.69888	7.799152	3.803217
137.2528	88.33169	48.92113	7.10027	-0.76442	7.864689	3.826219
121.98	84.68423	37.2958	7.232739	-0.56781	7.800547	3.84822
91.50002	70.55864	20.94138	7.298974	-0.43673	7.735708	3.870221
66.98491	46.15386	20.83106	7.232739	-0.63335	7.866085	3.892222
59.05355	28.57976	30.47379	7.298974	-0.43673	7.735708	3.914224
51.51549	30.6356	20.87989	7.497678	-0.56781	8.065486	3.936225
50.92555	35.34413	15.58142	7.232739	-0.50227	7.73501	3.958226
58.07033	36.27257	21.79776	7.298974	-0.63335	7.932319	3.980227
70.19678	40.91479	29.282	7.232739	-0.56781	7.800547	4.002229
85.07628	51.06134	34.01494	7.232739	-0.56781	7.800547	4.02423
100.218	62.20265	38.01531	7.232739	-0.56781	7.800547	4.046231
113.5898	70.69127	42.89856	7.298974	-0.69888	7.997856	4.068233
125.5852	75.99666	49.58854	7.232739	-0.56781	7.800547	4.093234
132.5989	78.64936	53.94952	7.232739	-0.56781	7.800547	4.115235
136.794	79.5778	57.21618	7.232739	-0.56781	7.800547	4.147237
138.236	80.24097	57.99507	7.497678	-0.43673	7.934412	4.169238
140.0714	82.36313	57.70827	7.166504	-0.56781	7.734313	4.191239
141.3824	85.28109	56.10128	7.298974	-0.69888	7.997856	4.213241
139.7437	88.0001	51.74356	7.232739	-0.56781	7.800547	4.235242
131.5501	87.20429	44.34581	7.232739	-0.56781	7.800547	4.257243
109.0014	79.84307	29.15838	7.10027	-0.56781	7.668078	4.279244
78.12814	60.0805	18.04765	7.232739	-0.56781	7.800547	4.301246
63.05201	36.07362	26.97839	7.034035	-0.69888	7.732918	4.323247
56.03833	28.57976	27.45857	7.298974	-0.56781	7.866782	4.345248
50.20452	33.6862	16.51832	7.431443	-0.43673	7.868177	4.367249
53.08865	35.21149	17.87715	7.232739	-0.63335	7.866085	4.389251
62.33097	37.1347	25.19628	7.298974	-0.63335	7.932319	4.411252
75.11292	44.23065	30.88226	7.431443	-0.43673	7.868177	4.433253
90.84454	55.37197	35.47257	7.232739	-0.56781	7.800547	4.455255
106.5762	65.98274	40.59342	7.166504	-0.69888	7.865387	4.477256
119.1615	73.4766	45.68485	7.298974	-0.56781	7.866782	4.500257
128.1416	77.25669	50.8849	7.232739	-0.56781	7.800547	4.522258
133.9754	79.24621	54.72919	7.166504	-0.69888	7.865387	4.54426
136.794	79.71043	57.08355	7.232739	-0.56781	7.800547	4.566261
138.4327	80.37361	58.05908	7.232739	-0.56781	7.800547	4.588262
139.8748	82.36313	57.51163	7.166504	-0.56781	7.734313	4.610263
141.0546	84.02106	57.03357	7.232739	-0.63335	7.866085	4.633265
140.7269	87.07166	53.65523	7.431443	-0.43673	7.868177	4.655266
134.172	87.80115	46.37089	7.166504	-0.69888	7.865387	4.677268

114.3764	82.09786	32.27856	7.431443	-0.43673	7.868177	4.699269
83.04427	64.6564	18.38788	7.166504	-0.69888	7.865387	4.72127
63.64194	39.12422	24.51773	7.232739	-0.56781	7.800547	4.743271
57.15265	27.71763	29.43502	7.232739	-0.63335	7.866085	4.765273
49.94232	32.02826	17.91406	7.298974	-0.56781	7.866782	4.787274
51.58103	34.81359	16.76744	7.166504	-0.56781	7.734313	4.809275
59.70904	36.20625	23.50278	7.10027	-0.76442	7.864689	4.831276
72.94982	42.44008	30.50973	7.166504	-0.69888	7.865387	4.853277
88.15705	53.38245	34.77461	7.431443	-0.43673	7.868177	4.875278
103.4954	64.19217	39.30321	7.10027	-0.50227	7.602541	4.89728
116.7362	72.15026	44.58591	7.298974	-0.56781	7.866782	4.919281
126.5684	76.32825	50.24018	7.298974	-0.56781	7.866782	4.941282
132.7955	78.51672	54.2788	7.166504	-0.69888	7.865387	4.963284
136.4007	79.71043	56.69026	7.232739	-0.50227	7.73501	4.985285

## **Appendix B Laboratory procedure for mass transfer rate experiment**

### **Objectives**

1. Identify and use process control and monitoring instrumentation

Process control and data monitoring help ensure that a process operates in a way that maintains the desired result. You should be able to identify the primary instrumentation and controls for a process.

2. Obtain relevant data

Engineers must be able to design and conduct experiments and analyze and interpret data. You should be able to determine what data are needed to be able to calculate what you want to know.

3. Analyze and interpret data

Engineers must turn raw data into meaningful information. Engineering calculations are the common language of the profession that enables us to do this. In this experiment you will use *mass balances* to analyze the *mass transfer* in your blood oxygenator.

4. Identify and minimize potential hazards associated with the experiment

Every process poses safety hazards which must be identified and managed. You should be able to identify the safety hazards associated with the blood oxygenator system, know how to avoid these hazards, and how to control them.

5. Communicate your results using an appropriate technical reporting style

Engineers must be able to communicate effectively with different audiences including peers, managers and the general public. You will

prepare a technical report on blood oxygenator design that targets a peer engineering audience.

### **Introduction**

This laboratory is a continuation of the work you have done this semester in biological studies from an engineering perspective. You will operate a process mimicking a heart-lung machine (HLM) and patient such as is seen in cardiopulmonary bypass (CPB) surgery. The blood oxygenation and deoxygenation will take place in real medical hollow fiber membrane devices.

### **Background**

Blood oxygenation is the biological process of exchanging waste gas (mostly carbon dioxide) in the bloodstream with oxygen. Blood is pumped by the heart through the capillaries of the lungs. There, oxygen-rich/carbon dioxide-poor air is separated from the blood by a membrane. Because of the concentration differences between the air and blood, mass transfer occurs. The air in the lungs loses some (not all) of its oxygen and gains carbon dioxide while the blood gains oxygen and loses a little CO<sub>2</sub>. The oxygenated blood is then moved through the body to the cells, which consume oxygen and produce carbon dioxide. This is transported from the cells to the blood to the lungs, and then exhaled from the lungs. Figure 15 shows this as a membrane transfer process.



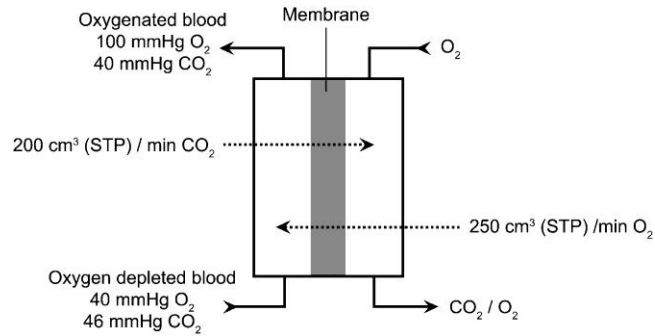

Figure 15. Actual data from a journal article (Stamatialis et al., Journal of Membrane Science, 2008) showing mass transfer in membrane. “mmHg” (millimeters of mercury) refers to the partial pressure of the gases in the blood, a proxy for their concentration. “cm<sup>3</sup> (STP) / min” (cubic centimeters at STP per minute) is a volumetric flow rate.

### System overview

The main flow path in the system is that of the blood analog (BA). The pump draws the liquid from the holding tank and forces it through the oxygenator and deoxygenator before it is returned to the holding tank.

A compressed oxygen cylinder supplies oxygen gas through a pressure-reducing regulator to the gas side of the oxygenator. It passes through and vents to the atmosphere. A compressed nitrogen cylinder performs the same function to the deoxygenator. A simplified schematic, called a **block diagram**, is shown in Figure 16.

In the body, the degree of blood oxygenation depends on the respiration rate of air and the blood flow rate. In the blood oxygenator system, the degree of blood oxygenation depends on the flow rate of the blood analog fluid and not the flow rate of the oxygen through the membrane. You will prove the second statement in this laboratory.

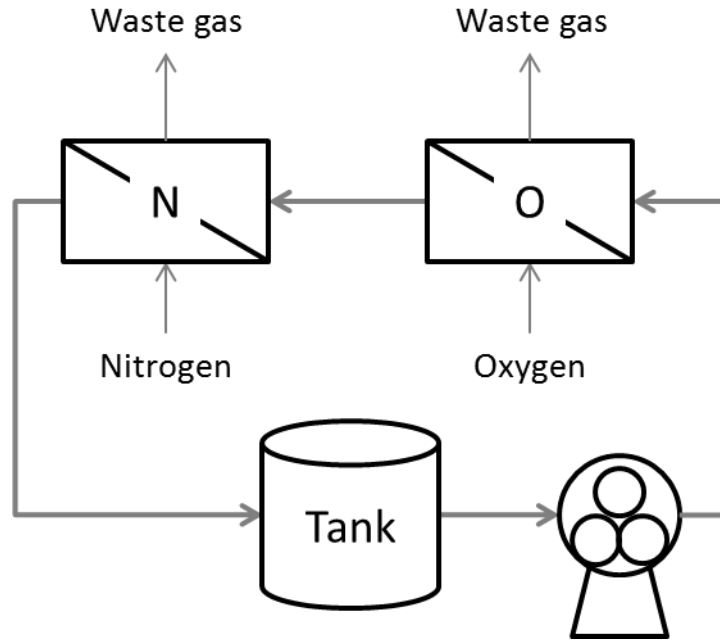

Figure 16. Block diagram of the system. Instrumentation and controls are not shown.

The following page contains a more detailed diagram (Figure 17) of the system in an idealized layout. The names of the parts are deliberately left out. Compare the figure to the system and fill in the names of each component.

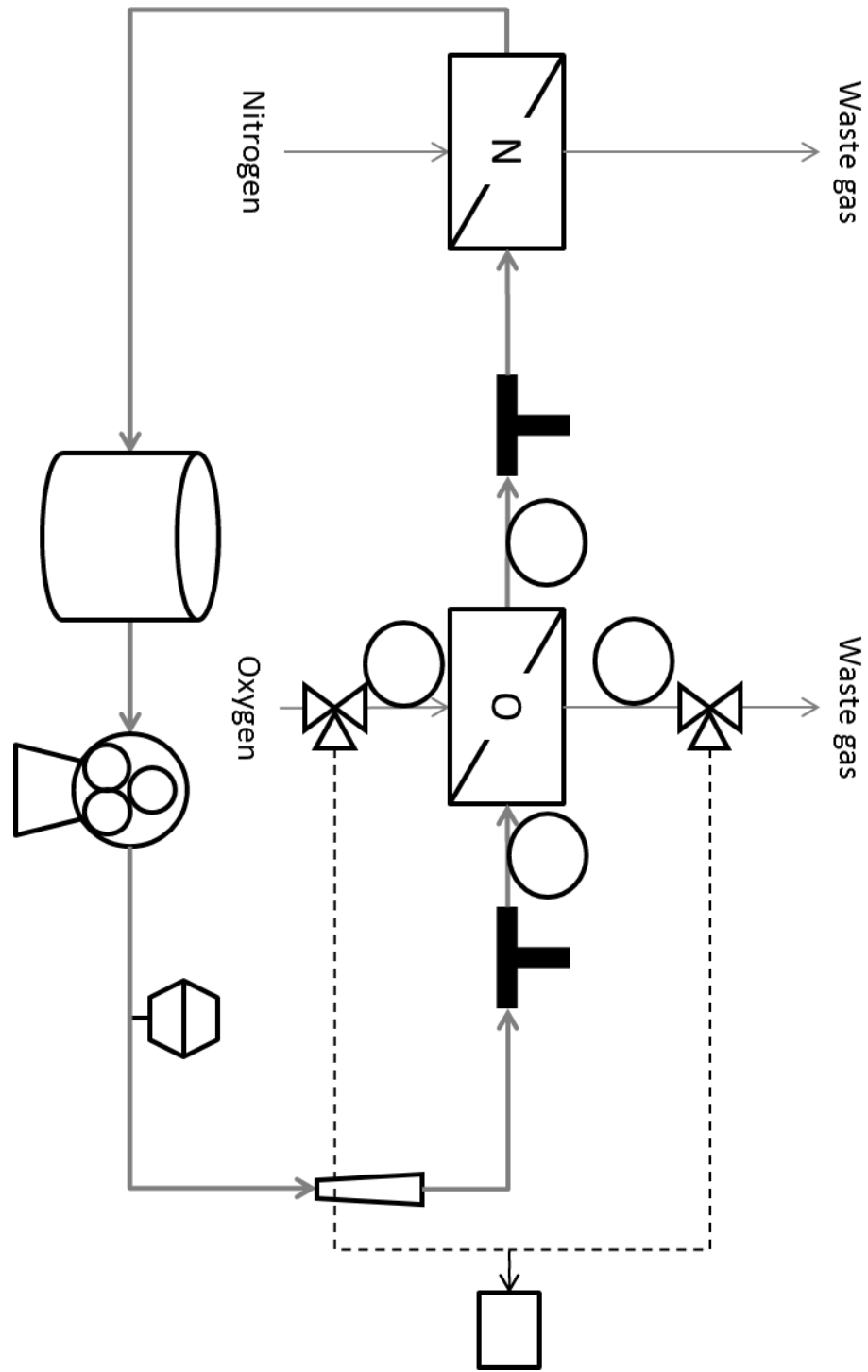

Figure 17. Detailed diagram of the system

## Controls

The system has three controls. Each of these will be demonstrated for you. Before you can use them you will have to answer questions on them to demonstrate competence.

- The pump controls

The speed of the pump controls the flow rate of the blood analog fluid. Set the dial to 30. First select the direction of flow (◀) and then press the “I” button to start the pump. After the pump has started, adjust the speed of the pump with the dial.

- The cylinder valves

The delivery pressure of the gas controls its flowrate. These gas cylinders have stem valves, regulator valves, and cutoff valves, shown in Figure 18. The stem valve turns the flow on and off. The regulator valve increases or decreases the delivery pressure. The cutoff valve allows you to quickly stop delivery of gas to the system.

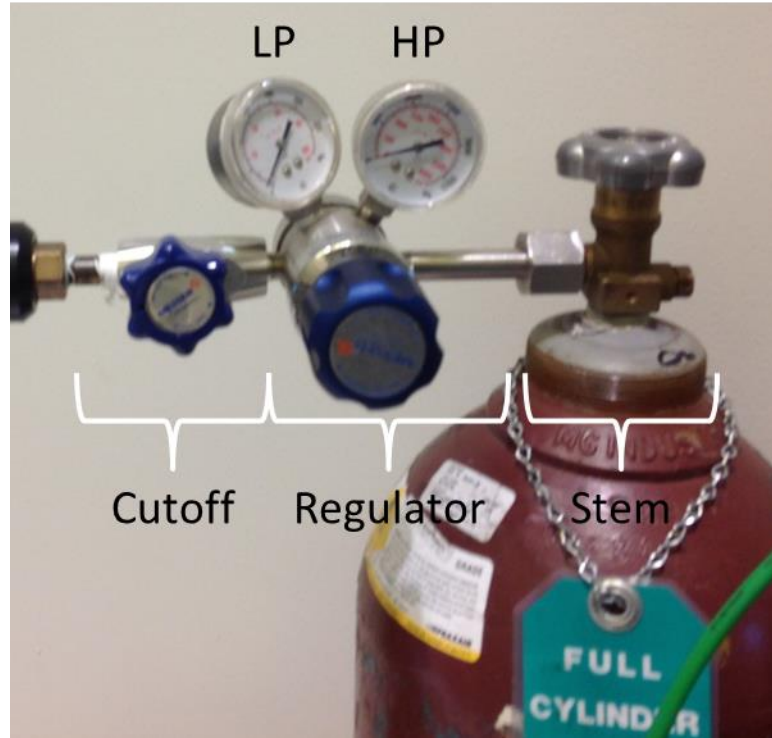

Figure 18. Valves on the oxygen cylinder. Turning the regulator valve clockwise will OPEN it, not close it. The stem valve should not be opened more than a quarter turn. Excess opening takes unnecessary time to close, such as in an emergency. LP gage indicates pressure of gas delivered to the system; HP gage indicates pressure in the cylinder.

- The gas sampling valves

These divert the gas from the inlet and outlet of the oxygenator. You cannot run the system while the inlet valve is set to “measure” because the oxygenator will not work without the gas supply.

### **Instrumentation**

Data for all process variables will be recorded manually during the experiment. Using the five manual display instruments below, you will take measurements of blood analog and oxygen flowrates, pressures of various streams, and oxygen concentrations in liquid and gas phases.

- The liquid flowmeter – measures liquid flowrate
- The gas flowmeters – measure gas flow rates
- The dissolved oxygen (DO) meter (2 of these) – measures inlet and outlet dissolved oxygen concentration in the liquid
- The oxygen-in-gas (OG) meter – measures inlet and outlet oxygen concentration in the gas

### **Safety!**

Engineering requires the use of materials and forces that can be dangerous if safety protocols are not followed. To reduce risks by developing more inherently safe processes is the constant concern of engineers. Because risk is never eliminated, engineers must also be aware of the dangers posed by the processes and materials they use.

In biomedical engineering, a major concern is pathogenicity of materials. However this is not a risk in our experiment due to the use of an analog liquid (water) rather than blood. Additionally the materials in the system have never been in contact with blood or other potentially pathogen-carrying liquids.

There are two potential hazards in this system; their risk can be minimized by following proper protocols:

- Compressed gas cylinders, which contain over 500 ft<sup>3</sup> compressed down to about 6 ft<sup>3</sup>. As the gages show, they are under enormous pressure (~2000 psig, well over 100 atm). Never use these without direct supervision.
- Venting of used gas to the atmosphere. The air turnover rate in the lab, 8 **ACH** (air changes per hour), should prevent dangerous concentrations of oxygen or nitrogen. However, don't inhale the gases or bring any open flame into the lab.

You should look up the **Safety Data Sheets (SDS)** –sometimes called Material Safety Data Sheets (MSDS) – for water, nitrogen and oxygen to become familiar with the risks that they represent. SDSs are the official descriptions of the material's basic physical properties, health, safety and environmental effects, basic treatment instructions and potential long term effects. Reading these will help you practice good **industrial hygiene** and be alert for dangerous situations.

Everyone should know the emergency shutdown:

- Hit the red button to turn off electric power
- Close the cylinder stem valves (clockwise)
- Evacuate if needed.

### **Operation**

Before you start, familiarize yourself with the system. After you have become familiar with the layout of the system and the operation of its controls and the use of the monitoring devices, you will perform the experiment. Record the data in the table on the next page, or in a similar one in your lab notebook.

Keep  $Q_N$  constant at 2.5 SCFH

$Q_{BA}$ [GPM]	$Q_O$ [SCFH]	$C_{in}$ [mg/L]	$y_{in}$ [1]	$C_{out}$ [mg/L]	$y_{out}$ [1]
1	1				
1	2				

Run number \_\_\_\_ out of \_\_\_\_.

Steady state has been reached when both concentrations change by less than 0.10 mg/L in 60 seconds.

Taken by:

---

---

---

---

Day and date:



### **Preparation**

1. Fill the mixing tank with at least 6 L of tap water.
2. Pour it into the holding tank and put the lid on top of it.
3. Check the pump hose is connected and clamped on both ends.
4. Set the dial to 30 and select the direction of flow (◀▶).
5. Get permission to turn the pump on.
6. Press the “**I**” button to start the pump.
7. Get permission to turn the pump on. Let the new BA flow through the system.
8. Turn the “equalizer” tank (located on the liquid flow line between the pump head and the rotameter) completely upside down and wait until the liquid line is completely free of bubbles.
9. Use the pump to set the flowrate to 1 GPM.

### **Mass transfer**

1. Check to see that the nitrogen regulator is completely closed (turns freely with no resistance).
2. Open the stem valve on the nitrogen cylinder.
3. Open the nitrogen regulator valve slowly until the LP gage (Figure 18) is up to 100 kPa.
4. Open the nitrogen cutoff valve.
5. Adjust the regulator until the nitrogen gas flowmeter reads 2.5 SCFH.
6. Open the stem valve on the oxygen cylinder.
7. Open the oxygen regulator valve slowly until the LP gage (Figure 18) is up to 100 kPa.

8. Adjust the oxygen regulator until the oxygen gas flowmeter reads the correct flowrate.
9. Turn the inlet gas sampling valve to point to the right.
10. Wait until the oxygen in gas meter reaches a stable reading and record it as “ $y_{in}$ ”
11. Turn the valve back to the left.
12. Slowly raise the pump to the correct flowrate.
13. Turn the outlet gas sampling valve to the right.
14. When the gas reading is stabilized, record it in your lab notebook as “ $y_{out}$ ”.
15. Turn the valve back to the left.
16. After the dissolved oxygen readings “ $C_{in}$ ” and “ $C_{out}$ ” have reached steady state, record them in your lab notebooks. Remember, assume steady state has been reached when the concentrations change by *less than* 0.10 mg/L in 60 seconds.
17. Change the gas and liquid flowrates and repeat until the table has been filled in.
18. Turn the pump off (“**O**”)
19. Turn the gases off at the stem valve.
20. Confirm with your instructor that you have finished the lab.

### **Data analysis**

You will use a spreadsheet program such as Microsoft Excel to analyze the mass transfer rate in the membrane unit. The purpose of a membrane like this is to allow mass to flow (“transfer”) from one stream to the other. To determine if that is happening, you will collect data and perform calculations for the amount of mass that has crossed (“permeated”) the membrane. These are shown in the next section.

You will have to do two **mass balances** around the membrane unit to determine how much mass has been transferred from the gas to the liquid. A mass balance is a single equation that accounts for all the mass that is flowing into, out of, or remaining within a system. We assume the system is at **steady state** (not changing over time) and therefore no mass is accumulating in the system. Then:

$$\text{mass in} = \text{mass out}$$

This works because of the **Law of Conservation of Mass**, a familiar statement that “mass cannot be created or destroyed”. We can also do **component balances**, which are mass balances on components of flows. For example:

$$\text{mass oxygen in} = \text{mass oxygen out}$$

We will use this to determine rate of oxygen mass transfer. Oxygen enters our system (and the lungs) by inhalation, and exits by crossing into the blood and being exhaled:

$$\dot{m}_{O,G,in} = \dot{m}_{O,G,out} + \dot{m}_{O,transfer}$$

$$\dot{m}_{O,L,in} + \dot{m}_{O,transfer} = \dot{m}_{O,L,out}$$

$\dot{m}$  represents mass flow rate (the dot on top of a variable commonly indicates “per time”, or rate). The subscript “G” represents gas and “L”, liquid. The first term of the equation is read “mass flow rate of oxygen, in the gas phase, at the system inlet”.

Rearranging:

$$\dot{m}_{O,G,in} - \dot{m}_{O,G,out} = \dot{m}_{O,transfer}$$

$$\dot{m}_{\text{O,transfer}} = \dot{m}_{\text{O,L,out}} - \dot{m}_{\text{O,L,in}}$$

You may recognize from algebra we have two equations and 4 unknown variables (commonly called **unknowns**). Converting to measurement variables of volumetric flowrate ( $Q$ ) and concentration ( $C$ ) we have:

$$\dot{m}_{\text{transfer}} = Q_{\text{O}}C_{\text{O}_2,\text{G,in}} - Q_{\text{O}}C_{\text{O,G,out}}$$

$$\dot{m}_{\text{transfer}} = Q_{\text{BA}}C_{\text{O}_2,\text{L,out}} - Q_{\text{BA}}C_{\text{O,L,in}}$$

Note that these are still dimensionally valid equations (that is, the units work out) because volumetric flow multiplied by concentration equals mass flow (prove it).

Going back to our two equations, we can factor out terms:

$$\dot{m}_{\text{transfer}} = Q_{\text{O}}(C_{\text{O,G,in}} - C_{\text{O,G,out}})$$

$$\dot{m}_{\text{transfer}} = Q_{\text{BA}}(C_{\text{O,L,out}} - C_{\text{O,L,in}})$$

Finally, we convert concentrations of oxygen in gas to volume fractions, using the ideal gas law. This gives us:

$$\dot{m}_{\text{transfer}} = \rho_{\text{O}}Q_{\text{O}}(y_{\text{in}} - y_{\text{out}})$$

$$\dot{m}_{\text{transfer}} = Q_{\text{BA}}(C_{\text{out}} - C_{\text{in}})$$

The symbol that looks like a “p” in the first equation is the lowercase Greek letter rho, which is used to represent density. The subscripts on the variables have been cleaned up by removing “O” for oxygen and the “L” and “G” for liquid and gas since we can tell

by inspection of the flowrate variables which equation is for liquid and which is for gas. Figure 19 below shows where all these variables fit on the block diagram.

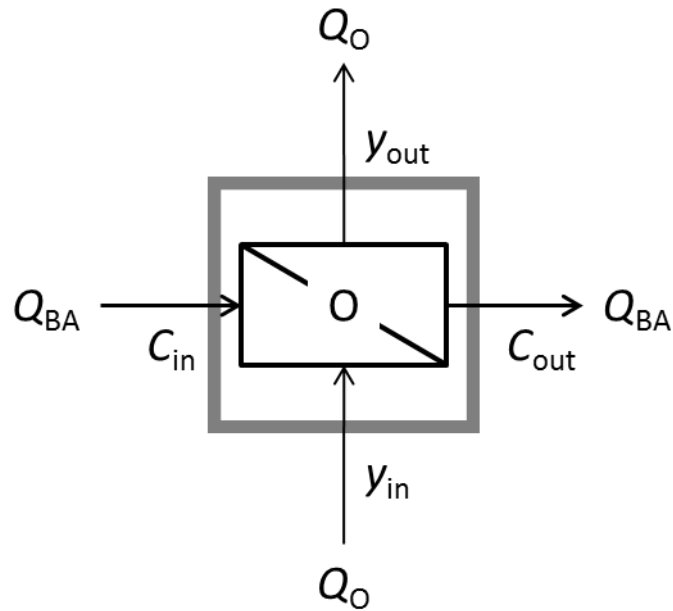

Figure 19. Flow variables and concentrations crossing a system boundary drawn around the oxygenator.

Now we have two equations and one unknown,  $\dot{m}_{\text{transfer}}$  (you can easily look up the density of oxygen). Since we only need one equation to solve for the unknown, the system is **overspecified**. Mathematics dictates that the number of equations should equal the number of unknowns in order to have a unique solution. In real engineering systems, however, redundant measurements are commonly used as a method of cross-checking and correcting values. While useful, redundant measurements can lead to two different calculated values for a single variable, which can be confusing. Experience is required to choose the more reliable value when redundant values differ significantly.

Calculate and report the value of  $\dot{m}_{\text{transfer}}$  using both equations and report both values. Are the values the same? Why or why not?

**To include in your final report**

You will include these following items in your final report on blood oxygenators. You do not have to give them in this order, but they must be present.

1. The full system diagram with complete labels.
2. The value of  $\dot{m}_{\text{transfer}}$  using both equations and an explanation of their difference, if any.

## Appendix C Evaluation questions for experiment one

1. What does “mass transfer” mean?
  - a. A net movement of mass from one location to another
  - b. The process of changing mass into weight
  - c. Movement of mass between phases
  - d. Mass flowing across a system boundary
  
2. An adult human blood flowrate through the heart is approximately:
  - a. 1 L/min
  - b. 5 L/min
  - c. 8 L/min
  - d. 10 L/min
  
3. If the membrane area in a hollow fiber oxygenator is doubled, the rate of oxygen transfer to the deoxygenated blood contacted by oxygen would
  - a. decrease by a factor of 2
  - b. stay the same
  - c. increase by a factor of 2
  - d. increase by a factor of diameter squared

4. The term describing dissolved oxygen movement through a liquid such as blood, from a high concentration to a low concentration:
  - a. rediffusion
  - b. perfusion
  - c. associated rediffusion
  - d. diffusion
  
5. In a hollow fiber membrane oxygenator, pure oxygen flows at a high flow rate through the tubes. The membrane is thin and oxygen fills the pores of the membrane. On the other side of the membrane (shell side), blood flows through the unit. How could the mass transfer rate of oxygen to the blood be increased?
  - a. increase the gas flow rate through the oxygenator
  - b. increase the liquid flow rate through the oxygenator
  - c. decrease the gas flow rate through the oxygenator
  - d. decrease the liquid flow rate through the oxygenator
  
6. The solubility of a gas in a liquid
  - a. increases as the temperature increases
  - b. does not depend on temperature
  - c. decreases as the temperature increases



d. decreases as the pressure increases

7. Write an equation for the rate of oxygen transfer to blood in a hollow fiber oxygenator. In the diagram below,  $C$  is the concentration of oxygen in the blood (mg/L),  $\dot{V}$  is the volumetric flow rate of the blood (L/min), and  $\dot{m}_{xfer}$  is the rate of oxygen transfer to the gas (mg/min).

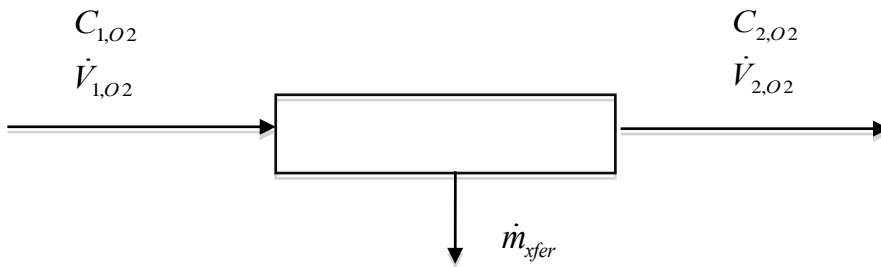

8. What are three functions of a heart-lung machine?
- \_\_\_\_\_
  - \_\_\_\_\_
  - \_\_\_\_\_
9. There are some benefits to using a higher blood flowrate of blood in a hollow fiber blood oxygenator. Yet it is not desirable to operate the blood oxygenators at the fastest flow rate the pump can achieve. Why?
10. What is a typical flow rate used in a hollow fiber blood oxygenator during open heart surgery for an adult, and why?

11. What body temperature is typically maintained by the heart lung machine during open heart surgery, and why?

## **Appendix D Laboratory procedure for friction factor experiment**

### **Objectives**

1. Identify and use process control and monitoring instrumentation

Process control and data monitoring help ensure that a process operates in a way that maintains the desired result. You should be able to identify the primary instrumentation and controls for a process.

2. Obtain relevant data

Engineers must be able to design and conduct experiments and analyze and interpret data. You should be able to determine what data are needed to be able to calculate what you want to know.

3. Analyze and interpret data

Engineers must turn raw data into meaningful information. Engineering calculations are the common language of the profession that enables us to do this. In this experiment you will calculate the *friction factor* and *Reynolds number*.

4. Communicate your results using an appropriate technical reporting style

Engineers must be able to communicate effectively with different audiences including peers, managers and the general public. You will prepare a technical report on pressure losses in the blood oxygenator.

### **Introduction**

This laboratory is a continuation of the work you did in your freshman engineering courses in biological studies from an engineering perspective. You will operate a process mimicking a heart-lung machine and patient such as is seen in cardiopulmonary bypass surgery.

## Background

Blood oxygenation is the biological process of exchanging waste gas (mostly carbon dioxide) in the bloodstream with oxygen. Blood is pumped by the heart through the capillaries of the lungs where mass transfer takes place. In the

## System overview

The flow path in the system is that of the blood analog. The pump draws the liquid from the holding tank and forces it through the oxygenator and deoxygenator before it is returned to the holding tank, shown in Figure 20.

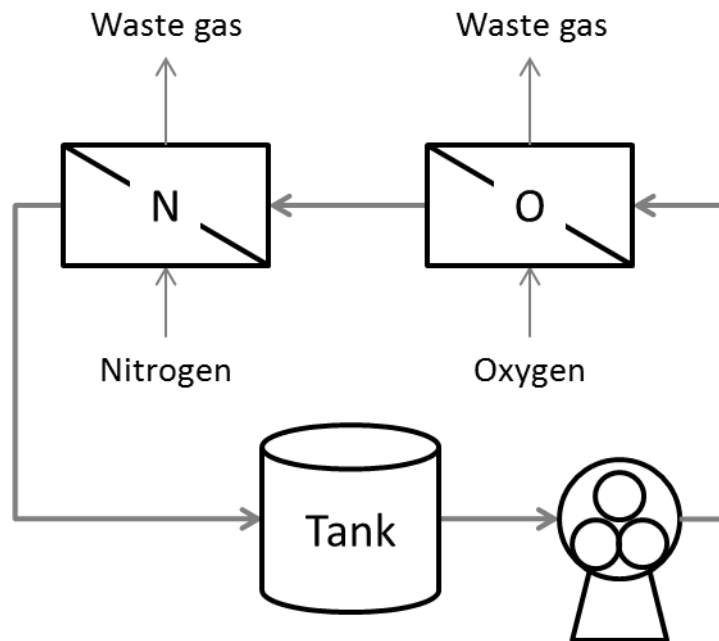

Figure 20. Block diagram of the system. Instrumentation and controls are not shown.

## Controls

The pump controls are the only ones used in this laboratory. The speed of the pump controls the flow rate of the blood analog fluid. Set the dial to 30. First select the

direction of flow (↺) and then press the “I” button to start the pump. After the pump has started, adjust the speed of the pump with the dial.

### **Instrumentation**

Data for all process variables is recorded automatically using the process monitor installed on the PC. To use it, start the PC and log in with your usual username and password. Open the file named “BLOX” that is located on the Desktop. Instructions are present in the LabVIEW program on how to use the instrumentation. Data from the pressure transducers is saved to \*.CSV files that can be opened in Microsoft Excel or a similar spreadsheet program.

### **Safety!**

In biomedical engineering, a major concern is pathogenicity of materials. However this is not a risk in our experiment due to the use of an analog liquid made of water and glycerine rather than blood. Additionally the materials in the system have never been in contact with blood or other potentially pathogen-carrying liquids.

Everyone should know the emergency shutdown:

- Hit the red button to turn off electric power
- Close the cylinder stem valves (clockwise)
- Evacuate if needed.

### **Operation**

Before you start, familiarize yourself with the system. After you have become familiar with the layout of the system and the operation of its controls and the use of the monitoring devices, you will perform the experiment.

### **Preparation**

1. Prepare a well-mixed blood analog solution using the mixing tank. The total volume of the blood analog solution should be between 7 and 8 liters.
2. Pour it into the holding tank and put the lid on top of it.
3. Check the pump hose is connected and clamped on both ends.
4. Set the dial to 30 and select the direction of flow (◀▶).
5. Get permission to turn the pump on.
6. Press the “**I**” button to start the pump.
7. Get permission to turn the pump on. Let the new BA flow through the system.
8. Turn the “equalizer” tank (located on the liquid flow line between the pump head and the rotameter) completely upside down and wait until the liquid line is completely free of bubbles.
9. Use the pump to set the flowrate to 1 GPM.

### **Pressure drop**

1. Check to see that the nitrogen regulator is completely closed (turns freely with no resistance).
2. Open the stem valve on the nitrogen cylinder.
3. Open the nitrogen regulator valve slowly until the LP gage (Figure 18) is up to 100 kPa.
4. Open the nitrogen cutoff valve.
5. Adjust the regulator until the nitrogen gas flowmeter reads 2.5 SCFH.
6. Open the stem valve on the oxygen cylinder.

7. Open the oxygen regulator valve slowly until the LP gage (Figure 18) is up to 100 kPa.
8. Adjust the oxygen regulator until the oxygen gas flowmeter reads the correct flowrate.
9. Slowly raise the pump to the correct flowrate.
10. In LabVIEW, begin collecting process data. Save the file to your Desktop with a “.csv” extension.
11. Change the liquid flowrate and repeat until each flowrate has been run three times.
12. Turn the pump off (“”)
13. Turn the gases off at the stem valve.
14. Empty the blood analog liquid into the mixing tank and pour it down the sink drain.
15. Repeat the preparation step to mix the next blood analog.

### **Data analysis**

You will use a spreadsheet program such as Microsoft Excel to analyze the pressure drop in the system.

### **To include in your final report**

You must include the graph of the Fanning friction factor as a function of the Reynolds number for all blood analogs and flowrates.

## **Appendix E Laboratory procedure for mass transfer correlation experiment Objectives**

### 1. Identify and use process control and monitoring instrumentation

Process control and data monitoring help ensure that a process operates in a way that maintains the desired result. You should be able to identify the primary instrumentation and controls for a process.

### 2. Obtain relevant data

Engineers must be able to design and conduct experiments and analyze and interpret data. You should be able to determine what data are needed to be able to calculate what you want to know.

### 3. Analyze and interpret data

Engineers must turn raw data into meaningful information. Engineering calculations are the common language of the profession that enables us to do this. In this experiment you will create a correlation of three dimensionless groups, the *Sherwood*, *Reynolds* and *Schmidt* numbers.

### 4. Communicate your results using an appropriate technical reporting style

Engineers must be able to communicate effectively with different audiences including peers, managers and the general public. You will prepare a technical report on pressure losses in the blood oxygenator.

## **Introduction**

This laboratory is an application of the mass transfer theory you have been learning to a biomedical engineering device. You will operate a process mimicking a heart-lung machine and patient such as is seen in cardiopulmonary bypass (CPB) surgery. The blood



oxygenation and deoxygenation will take place in real medical hollow fiber membrane devices.

### **Background**

One of the major applications of blood oxygenators is the oxygenation of blood in a heart lung machine system. Heart lung machines are often utilized to help support a patient during cardiopulmonary bypass. They have been utilized since 1953, when John H. Gibbon of the Jefferson University Medical Center in Philadelphia performed a total cardiopulmonary bypass on an 18 year old woman in order to close an atrial defect. Since then, millions of patients around the world have had heart defects operated on, as technology for blood oxygenators have improved through the generations. Today's blood oxygenators are commonly composed of microporous hollow fiber membranes which are capable of efficiently separating the liquid blood and oxygen gas phases. In these type of membranes, the liquid blood typically flows on the outside of the membrane while gas (usually oxygen) flows on the inside or lumen. These types of membranes are designed to be hydrophobic, which allows the pores in the membrane to be filled with gas, which results in minimal mass transfer resistance in the membrane itself.

### **System design and operation**

The system uses 2 hollow fiber membranes to serve as an oxygenator and a de-oxygenator of the system, acting as both the HLM and patient respectively. A CAD drawing of the system front panel to scale is represented below in Figure 21. A picture of the oxygenator is shown in Figure 22.

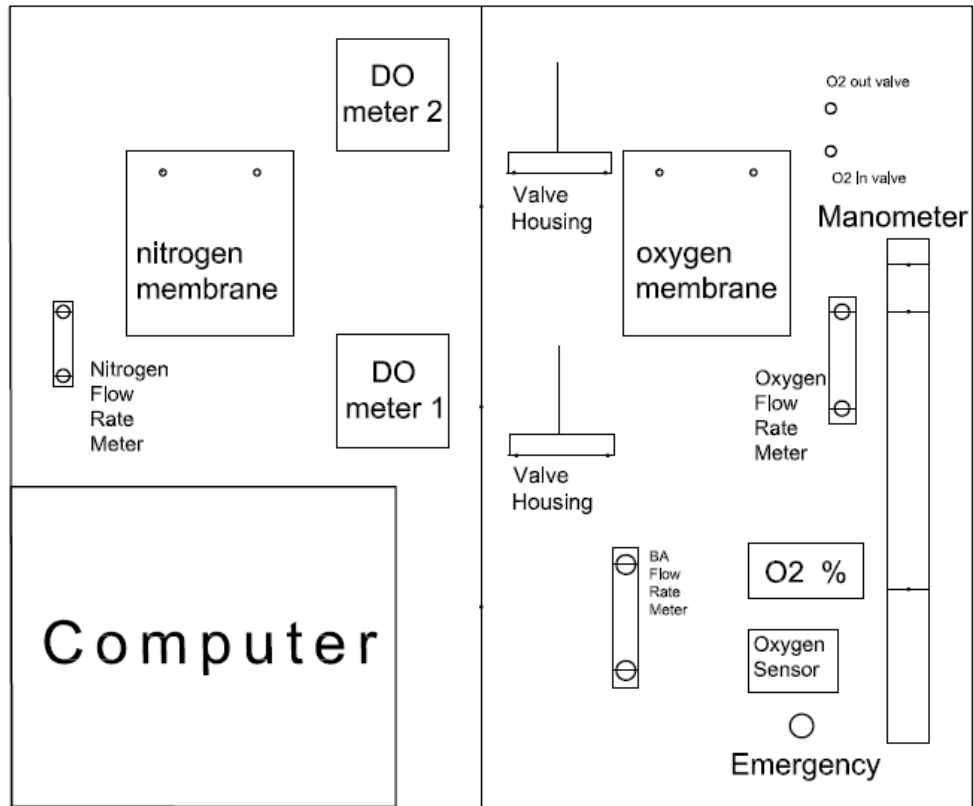

Figure 21. Drawing of system front panel

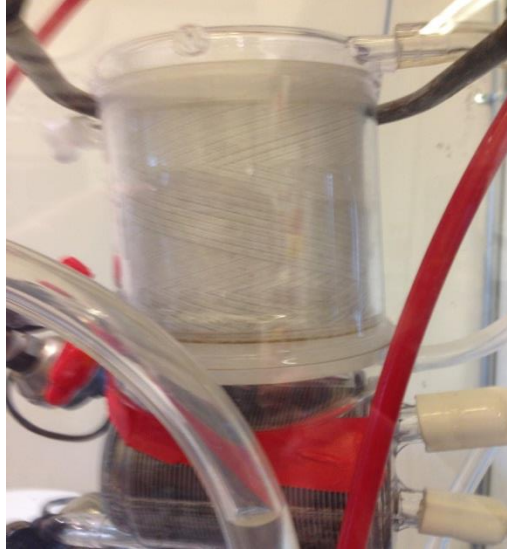

Figure 22. Blood oxygenator membrane unit. This unit is used to oxygenate the blood analog. An identical one is used to deoxygenate the blood analog.

A picture of the system is shown in Figure 23.

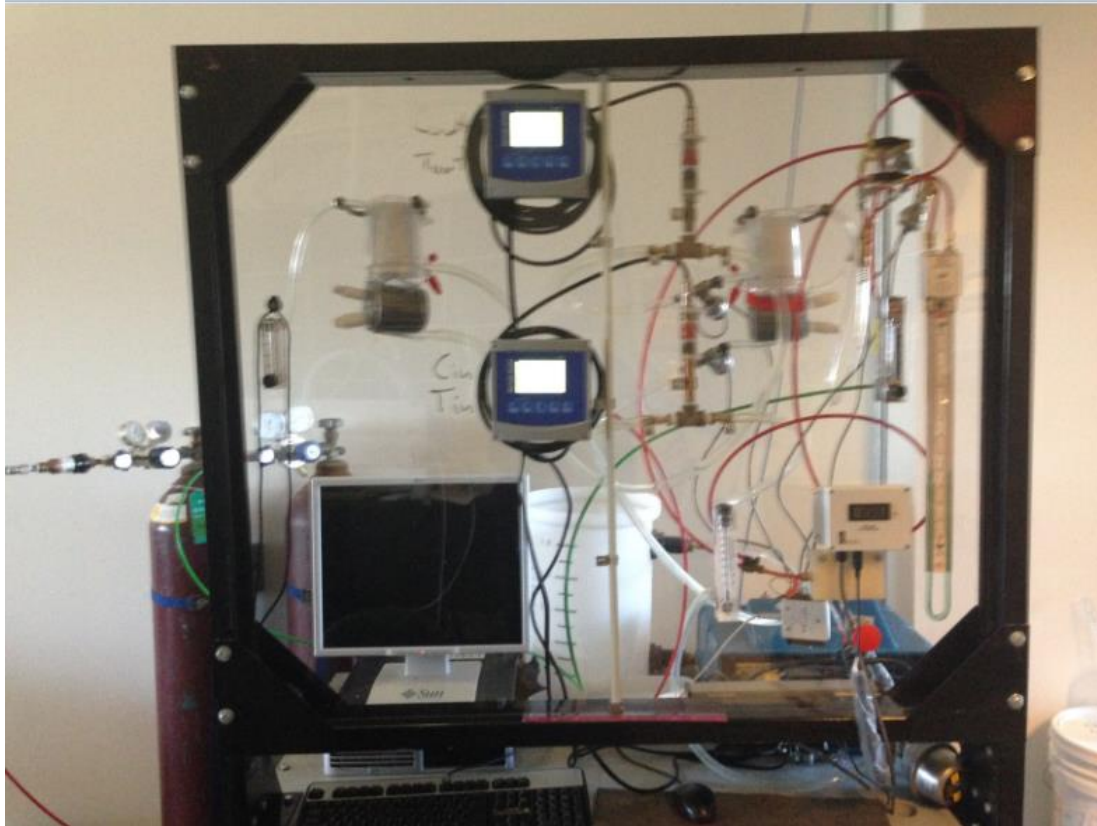

Figure 23. The oxygenator testing system. Concentration sensors, flow meters, manometer and membrane units are mounted on the front panel. The nitrogen and oxygen gases are supplied by the cylinders seen behind the assembly. The pump rests on the table behind the panel and pumps the blood analog from the holding tank through the two membranes and back to the tank.

### Controls

The system has two sets of controls. Each of these will be demonstrated for you. Before you can use them you will have to answer questions on them to demonstrate competence.

- The pump controls

The speed of the pump controls the flow rate of the blood analog fluid. Set the dial to 30. First select the direction of flow (◀) and then press the “I”

button to start the pump. After the pump has started, adjust the speed of the pump with the dial.

- The cylinder valves

The delivery pressure of the gas controls its flowrate. These gas cylinders have stem valves, regulator valves, and cutoff valves, shown in Figure 18.

The stem valve turns the flow on and off. The regulator valve increases or decreases the delivery pressure. The cutoff valve allows you to quickly stop delivery of gas to the system.

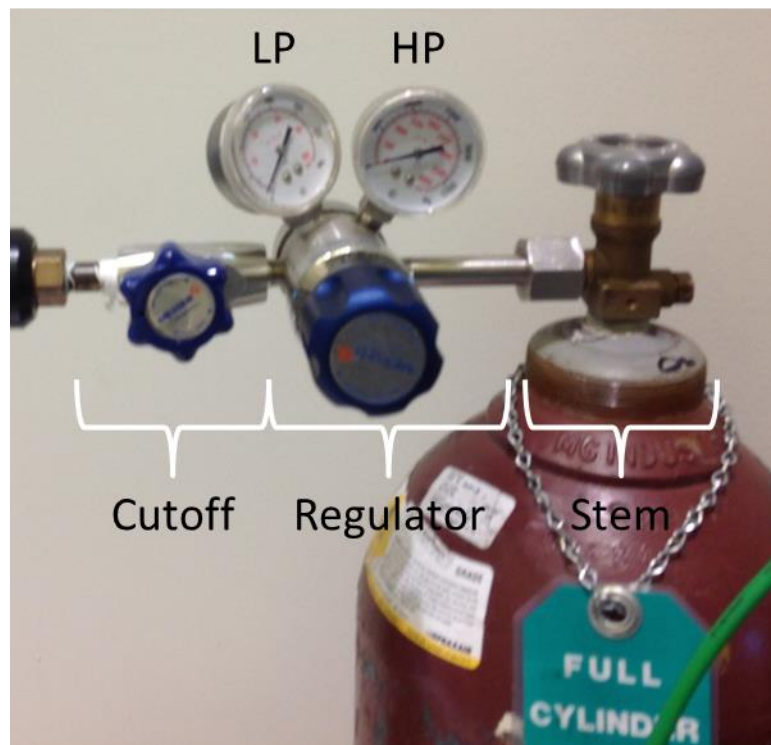

Figure 24. Valves on the oxygen cylinder. Turning the regulator valve clockwise will OPEN it, not close it. The stem valve should not be opened more than a quarter turn. Excess opening takes unnecessary time to close, such as in an emergency. LP gage

indicates pressure of gas delivered to the system; HP gage indicates pressure in the cylinder.

### **Instrumentation**

Data for all process variables will be recorded manually during the experiment. Using the three instruments below, you will take measurements of blood analog flowrates and oxygen concentrations in the inlet and outlet of the oxygenator.

- The liquid flowmeter – measures liquid flowrate
- The dissolved oxygen (DO) inlet meter – measures inlet dissolved oxygen concentration in the liquid
- The dissolved oxygen (DO) outlet meter – measures outlet dissolved oxygen concentration in the liquid

### **Safety!**

We use a blood analog liquid of water or water/glycerine. These substances are non-pathogenic. Additionally the materials in the system have never been in contact with blood or other potentially pathogen-carrying liquids.

There are two potential hazards in this system:

- Compressed gas cylinders, which are under enormous pressure (~2000 psig, well over 100 atm). Never use these if you are unsure about their safe operation.
- Venting of used gas to the atmosphere. The air turnover rate in the lab, 8 air changes per hour, should prevent dangerous concentrations of oxygen or nitrogen. However, don't inhale the gases or bring any open flame into the lab.

Everyone should know the emergency shutdown:

- Hit the red button to turn off electric power
- Close the cylinder stem valves (clockwise)
- Evacuate if needed.

### **Operating procedure**

The operating procedure is given below. Note that you cannot work alone: at least one other person must be in the lab, or within shouting distance. This is a departmental safety requirement.

1. Prepare a well-mixed blood analog (water/glycerine) solution using the mixing tank. The total volume of the blood analog solution should be between 7 and 8 liters.
2. Pour the blood analog into the holding tank.
3. Make sure the oxygen and nitrogen gas lines are connected to their proper flow meters.
4. Turn the stem valves of the oxygen and nitrogen storage tanks counter-clockwise. In addition, open the secondary valve so that the low pressure gauge reads about 100 kPa.
5. Set the flow rate of oxygen to 1 SCFH and the flow rate of nitrogen to 2.5 SCFH by turning the knob on their respective flow meters.
6. Plug the pump's power cord into the outlet and turn the pump on. Set the liquid (blood analog) flow rate ( $Q_{BA}$ ) to the first run.

7. Allow the system to reach steady state. For this experiment, steady state was assumed to have been achieved when the outlet oxygen concentration changed less than 0.1 mg/L for 1 minute. Record the inlet the outlet oxygen concentrations ( $C_{in}$  and  $C_{out}$ ) from the DO meters.
8. Once all data has been recorded, repeat step 7 for duplicate runs at same wt% of blood analog solution.
9. Once the first blood analog solution has done, prepare a new solution and repeat step 1 to 8 until all data has been recorded for 7 different solutions.

Below is a template you may use to record your data at a certain fluid composition:

BA\_\_\_  $Q_L$        $C_{in}$        $T_{in}$        $C_{out}$        $T_{out}$

Run #    [GPM]    [mg/L]    [°C]    [mg/L]    [°C]

1

2

3

**Shut down procedure:**

1. Turn off the pump, disconnect the power of pump, and close the oxygen storage tank stem valve.
2. Drain the system by using needle-nose pliers to undo the clamps holding the liquid line together. Make sure a bucket is placed underneath to collect the solution.



3. Run the pump to drain the rest of the system's fluids into the bucket. Stop and unplug the pump.
4. Reconnect the liquid line and purge both HFM units with nitrogen gas by placing the nitrogen gas line into each gas flow rate meter.
5. After purging the system with nitrogen, close the stem valve of the nitrogen storage tank.

### **Dimensionless Number Analysis**

You will plot a relationship between several dimensionless numbers at each liquid flow rate that the system operates. Specifically, you will create a plot of  $Sh/Sc^{1/3}$  v.  $Re$ , where  $Sh$  is the Sherwood number,  $Sc$  is the Schmidt number, and  $Re$  is the Reynolds number.

The Reynolds numbers is defined as:

$$Re = \frac{\rho v D}{\mu}$$

where,  $\rho$  is the fluid density,  $\mu$  is the fluid viscosity,  $v$  is the apparent velocity, and  $D$  is the hydraulic diameter.  $v$  and  $D$  are defined below:

$$v_d = \frac{4(1 - \varepsilon)Q_L}{N_f \varepsilon \pi d^2}$$

$$D = d \frac{\varepsilon}{1 - \varepsilon}$$

where  $\varepsilon$  is the void fraction,  $Q_L$  is the liquid volumetric flow rate,  $d$  is the fiber diameter, and  $N_f$  is the number of fibers in the hollow fiber membrane defined below:

$$N_{\text{fiber}} = \frac{A}{\pi d L}$$

where  $A$  is the membrane surface area and  $L$  is the length of a single fiber. In addition to calculating Reynolds number, after collecting concentration data, you will calculate the Sherwood number which is defined as:

$$Sh = \frac{Kd}{D_{OA}}$$

where  $D_{OA}$  is the mass diffusivity of oxygen in the analog. The mass transfer coefficient  $K$  for this system is defined as:

$$K = \frac{Q_L}{A} \ln \left( \frac{c_{in} - c^*}{c_{out} - c^*} \right)$$

where  $C_{in}$  and  $C_{out}$  are the oxygen concentrations of the liquid in and out of the membrane respectively.  $C^*$  is the saturation concentration of the oxygen in the liquid as if it were at equilibrium with the gas phase. Finally, the Schmidt number is defined as:

$$Sc = \frac{\mu}{\rho D_{OA}}$$

Table 8 below lists system data. Water and glycerin solution density and viscosity at each composition should be looked up using external reliable sources.

Table 8. System values for calculations.

Variable (units)	Value
Mass Diffusivity (m <sup>2</sup> /s)	$2.10 \times 10^{-9}$
Void Fraction (1)	0.45
Fiber Diameter (μm)	300
Length of Fiber (mm)	76.2
Membrane Surface Area (m <sup>2</sup> )	2.5

**To include in your report**

1. Percent error of mass transfer rates in Equation 6 for all of the compositions and flow rates tested. Is mass conserved in this system? Explain any discrepancies.
2. Graph of  $Sh/Sc^{1/3}$  v.  $Re$  including correlation line, equation and  $R^2$  value.